

[www.Alltraxinc.com](http://www.Alltraxinc.com)

# ALLTRAX

PERFORMANCE MOTOR CONTROLLERS

## Operators Manual AC Controller RXV



Alltrax Inc

1111 Cheney Creek Road, Grants Pass, OR 97527 Ph: 541-476-3565

Web Site: <http://www.alltraxinc.com>

©ALLTRAX INC 2024 - All Rights Reserved

Contact Alltrax:

Phone: 541-476-3565 EXT 3

Email:

Tech Support: [helpdesk@alltraxinc.com](mailto:helpdesk@alltraxinc.com)

Orders: [orders@alltraxinc.com](mailto:orders@alltraxinc.com)

General Inquires: [info@alltraxinc.com](mailto:info@alltraxinc.com)

Website:

<http://www.alltraxinc.com>

Facebook:

<http://www.facebook.com/AlltraxInc>

Twitter:

<http://www.twitter.com/Alltraxinc>

Installation Instructions for both the 35 pin and 23pin style RXV controllers should be included with your controller but can also be found on our website.

\*\*\*\*\*

This controller **WILL NOT WORK** with the samsung lithium batteries found on the E-Z-GO Elite cars.

\*\*\*\*\*

# TABLE OF CONTENTS

---

<b>WARNINGS</b>	<b>5</b>
<b>AC TECHNICAL SPECIFICATIONS</b>	<b>6</b>
<b>TERMS AND DEFINITIONS</b>	<b>7</b>
<b>REQUIRED COMPONENT INFO</b>	<b>9</b>
<i>SOLENOID/CONTACTORS</i>	<b>10</b>
<i>MAIN FUSE</i>	<b>11</b>
<i>WIRING</i>	<b>12</b>
<i>HIGH CURRENT</i>	<b>13</b>
<i>TEMP SENSOR</i>	<b>14</b>
<i>SPEED SENSOR</i>	<b>14</b>
<b>HARNESS PINOUTS</b>	<b>15</b>
<i>35 PIN AMPSEAL (RXV)</i>	<b>15</b>
<i>PINOUT TABLE 1/2</i>	<b>16</b>
<i>PINOUT TABLE 2/2</i>	<b>17</b>
<i>23 PIN AMPSEAL (DANAHER)</i>	<b>18</b>
<i>PINOUT TABLE 1/2</i>	<b>19</b>
<i>PINOUT TABLE 2/2</i>	<b>20</b>
<b>CONTROLLER DIMENSIONS</b>	<b>21</b>
<i>TOP DOWN VIEW</i>	<b>21</b>
<i>SIDE VIEW</i>	<b>22</b>
<i>FRONT VIEW</i>	<b>22</b>
<b>CONTROLLER DRAWINGS</b>	<b>23</b>
<i>RXV CURTIS SIMPLE</i>	<b>24</b>
<i>RXV CURTIS SCHEMATIC</i>	<b>25</b>
<i>RXV DANAHER SIMPLE</i>	<b>26</b>
<i>RXV DANAHER SCHEMATIC</i>	<b>27</b>
<b>LED BLINK CODES</b>	<b>29</b>
<i>THROTTLE AND BRAKE CODES</i>	<b>29</b>
<i>ALARM CODES</i>	<b>30</b>
<i>CODE DEFINITIONS</i>	<b>31</b>
<b>WARRANTY STATEMENT</b>	<b>33</b>

# WARNINGS

---



## GENERAL WARNINGS

---

### Safety Notes:

When working on electric vehicles, sudden unexpected events can occur, it's recommended to:

- Place the drive axle on jack stands—wheels off the floor.
- When working on wiring or batteries, always remove rings, watches and secure dangling clothing/hair/jewelry.
- Use the proper safety equipment, eye protection, and insulated tools.
- Never connect a computer while the vehicle is being charged.
- Disconnect batteries before installing or working on the Alltrax controller.
- Wear safety glasses.
- Because hydrogen can build up due to gassing from the batteries, work in a well ventilated area.
- Make sure the battery pack is fused.
- Do not clean the controller with a high PSI pressure washer.
- When cleaning batteries, take precautions to keep the battery acid from splashing on the controller.

### CAUTION:

It is the installer's responsibility to ensure the correct equipment (i.e. wire, motor, solenoid, fuse etc) is installed in the vehicle. Equipment should be sized correctly for planned usage. Failure to do so could pose a significant risk of explosion, fire, property damage and serious injury or death.

## READ AND SAVE THESE INSTRUCTIONS

# WARNINGS

---



## **USABILITY STATEMENT**

---

Alltrax Inc's lines of AC Induction and PMAC Motor Controllers are intended for use with brushless motors only. Any application or usage that does not meet these criteria WILL NOT be covered by warranty. Also, any requests for design assistance or technical support outside the scope of the product intended use may be denied. Alltrax assumes no liability for any damage or injury as a result of use of the motor controllers in a non-traction or process motor application. See the warranty at the end of this manual.

**WARNING:** Use of this product for other than these specified uses may be highly dangerous and lead to serious injuries or death.



## **VOLTAGE SETTINGS**

The Alltrax AC1 controller works for a wide range of voltage applications. If you're running aftermarket lithium batteries, a higher voltage than standard or if this is a custom application we highly recommend you check your settings. For detailed instructions you can see our Toolkit operators manual. If the settings aren't correct it can limit torque, limit speed or even prevent operation.



## **THROTTLE SETTING**

It's important to make sure your throttle is correct for your application. The ITS throttle type should ONLY be used on DC EZGO applications being converted to the AC1 controller. All factory AC EZGO are 0-5v. Setting the controller for ITS when the car is equipped with a 0-5v throttle can potentially damage the factory throttle.

# AC1 SPECIFICATIONS



Model	1 Min (Phase Amps)	Continuous (Phase Amps)
AC1-48650	650	250

Type: 3 phase AC

Operating Frequency:

Controller Voltage, KSI & Reverse: 48v controllers = 16v - 60v  
72v controllers = 16v - 90v

Operating Temperature: -20c to 90c

Environmental Operating Temperature: -20c to 50c // 0F to 122F

Standby Current (Power up): 5mA

KSI & Rev Pin Input Current: 200mA max

Relay Drive Current: 4A max

Throttles Supported: 0-5k, 5k-0, E-Z-GO ITS,  
5k-0 3 Wire, 0-5v, USB  
Throttle, Absolute Mode

Terminal Bolt Torque: 60-80 in.lb (5-7ft.lb, 6.77-9.4nm)

Mounting Bolt Torque: 15-20 in.lb (1.25-1.75 ft.lb,  
1.7-2.25nm)

## **Terms and Definitions**

**IPM:** *Internal Permanent Magnet*

**SMPM:** *Surface Mount Permanent Magnet*

**KI:** *Integral Gain for PI/PID controllers*

**KP:** *Proportional Gain for PI/PID controllers*

**KD:** *Derivative Gain for PI/PID controllers*

**Quadrature:** *Most common type of Speed Sensor Signal used in AC Induction motor applications*

**ITS:** *Inductive Throttle System, used in DC EZGOs*

**KSI:** *Key switch input, refers to signal voltage from the KEY*

**Roll Detect:** *Is a feature that uses the speed sensor to determine whether or not the cart is moving with no active throttle.*

## **Unique Features**

### **Low Voltage Protection -**

If battery voltage falls below your set Under Voltage limit the controller will shut off the power supply completely to prevent the batteries from getting drained to the point of damaging themselves. If you plug the controller into the toolkit software you will get a large SHUTDOWN warning to notify you of what happened. You can bring power back by cycling the TOW/RUN or plugging your charger back into the cart.

#### ***Trigger Limits -***

*1v for one hour*

*5v under shutdown triggered in 5 minutes*

*10v under shutdown triggered in 1 minute*

### **Encoder Pulses/Revolution Constraint (Quadrature Encoder)**

The maximum encoder frequency the controller will accept is 10 kHz. To determine how fast this constraint will allow the motor to spin, use the equation:

$$\text{Max Speed Encoder Limit} = 600000 / \text{Encoder Size}$$

*(e.g., a motor with 128-pulse encoder can run up to 4587 rpm).*

### **Firmware Max Speed Constraint**

The maximum motor speed the controller will allow is 13,000 rpm.

$$\text{Max Sped RPM Limit} = 13,000$$

### **Brake lights and Reverse**

RXV carts that came with factory brake and reverse lights activate the brake lights whenever you are in reverse. The functionality will be the same with the Alltrax AC1 installed.



# COMPONENTS

---

**Heavy Duty Contactors**



**Main Fuse**



**Heavy Gauge Wires**

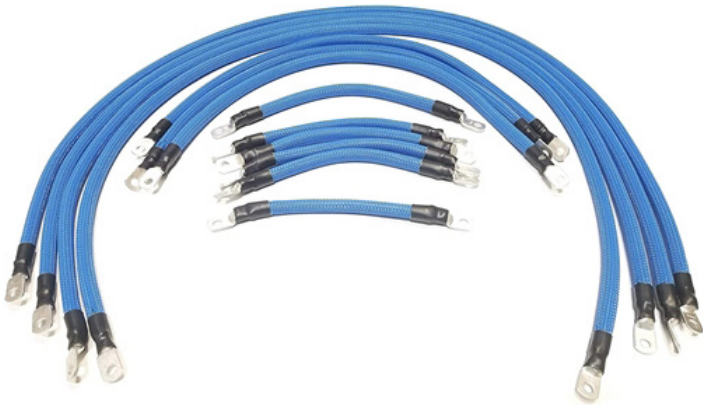

## ***Contactors (Solenoids)***

---



The solenoid is the primary disconnect of the battery pack in the case of the an emergency. In order to be effective, the solenoid needs to be properly rated for the current that will be drawn from the batteries. It is VERY important that the solenoid be rated correctly. It is the only way to disconnect the batteries from the motor/controller loop in case of a failure. Too small of a solenoid increases the likelihood that the contacts will weld together and not be able open.

When installing a new controller, Alltrax recommends the OEM solenoids be replaced with a heavy duty version. See below for suggested sizing of solenoid replacements.

As a regular part of a preventative maintenance plan, solenoids should be replaced every 3-5 years.



---

### **Heavy Duty 400A**

*(800-1000A inrush)*

A heavy duty solenoid is required when using any of the AC1 controllers. You need a minimum of 400A continuous and 800A inrush rating.

#### **Recommended Models**

MZJ400 (Shown)

SW200 (Albright)

SOL600

## Fuse

Any application where there is a battery pack, a fuse must be installed. A fuse will open the battery circuit and prevent any serious damage from occurring.

The fuse should be installed on or between the battery terminals. The main battery positive OR main battery negative OR in-between 2 batteries is an acceptable location for fuse installation. The fuse must be rated for pack voltage and fault current.



Controller Amperage	Fuse Style / Rating
650A	ANN / 400A

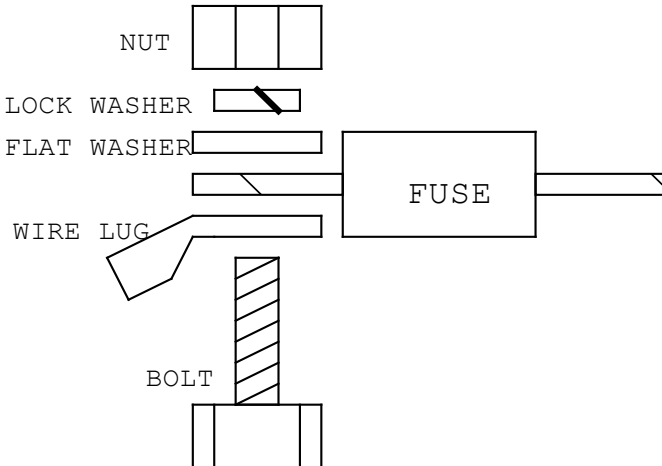

**Diagram: Fuse terminal hardware**

## **Wiring**

Wiring and battery health in an electric vehicle are very important and overlooked during performance upgrades. Wiring size is important for safety and proper operation of the vehicle. Undersized wires will affect the performance of controllers and can overheat. Wires should be crimped with proper sized terminals and tools to provide a clean low resistance connection.

Controller	Min. Wire AWG Standard Duty	Min. Wire AWG Heavy Duty
650A	2 AWG	1/0 AWG

### **Power Wiring**

When running wiring for the vehicle care must be taken for proper wire routing. Power wiring should be of proper sizing and ran as low in the framework of the vehicle as practical. Lengths of power wire runs need to be kept short and pairs of wires from common circuits should be grouped together to reduce EMC emissions. Secure all power wiring to the vehicle framework.

### **Motor Phase Wiring**

The three phase wires should be kept close to the same length and kept together as they run from the motor to the controller. For optimum reliability don't lay wire across other connections on the controller. Low current wires should not be run alongside the motor wiring or any high current wiring.

*\*\*\*Never swap motor phase wiring unless key is off and vehicle is not moving\*\*\**

# High Current Connections

TERMINAL	FUNCTION
B+	Battery positive to Controller
B-	Battery negative to Controller
R	Brake Resistor
U	Motor phase U
V	Motor phase V
W	Motor phase W

## LUG ASSEMBLY

The AC controller comes with 5-6 stainless steel 5/16-16 bolts for holding the high current terminals to the controller.

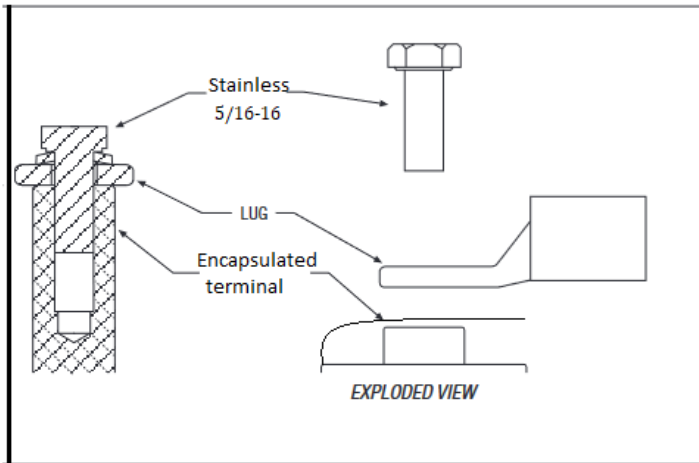

# Low Power Wiring

## Signal Wiring

Signal wires should be kept as short as practical. Care should be taken to protect the wires from sharp edges and rubbing. Consider the use of split loom or braided wire sheathing. Fasten bundles securely to framework. Do not route the signal wires together in the same bundle with power wires. **On E-Z-GO RXV applications you should not have to worry about rerouting your harness.** If you're adding wires for accessories this is good information to keep in mind.

## Temp Sensor

Induction motors come with a two wire temp sensor which the controller uses to monitor internal temps during operation. On DC conversions the temp sensor will run through the same harness connector as your speed sensor. The RXV Danaher uses pin #16 and the Curtis uses pin #8 to read the sensor. Pre 2016 RXV use the KTY-84, 2016 and up use a PT1000 temp sensor.

## ***Speed Sensor Information***

The speed sensor is a small group of wires attached to the side of the motor. Induction motors use a Quadrature signal that gives up to 64 readings per minute. Speed sensors are currently required. All E-Z-Go RXV carts come equipped with a speed sensor and the AC1 is pre programmed to work with it, no changes need to be made.

# Wire Harness Pinouts

## 35 PIN AMPSEAL CONNECTOR (E-Z-GO RXV/OEM)

All low power connections are made through a single 35-pin AMPSEAL connector. The mating plug housing is AMP p/n 776164-1 and the gold-plated socket terminals are AMP p/n 770520 (Strip form) and 770854-3 (loose piece). The connector will accept 0.5 – 1.25 mm (20 – 16 AWG) wire with a 1.7 – 2.7 mm diameter (thin-wall insulation). Seal any non-used connector positions that have the silo-diaphragm pierced with seal plug 770678-1.

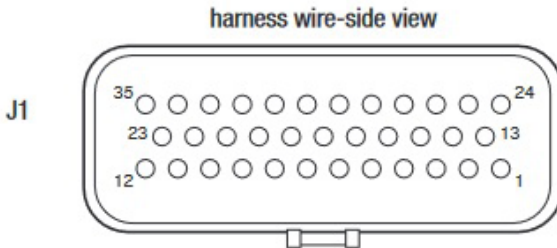

### Wiring Guidelines

#### ***Speed Sensor (Pins 7, 26, 31, 32)***

All four wires (+5V, Sensor A, Sensor B, and I/O ground) should be bundled together as they run between the motor and controller connections. These can often be run with the rest of the low current wiring harness.

#### ***CANbus (Pins 28, 29)***

It is recommended that the CAN wires be run as a twisted pair. The CANbus wiring should be kept away from the high current cables and cross them at right angles when necessary.

#### ***All other low power wiring***

The remaining low power wires should be run according to standard practices. Be sure to keep the input lines such as throttle, brake, temperature, and the above mentioned CAN/Speed Sensor signals separate from controller's output lines such as the coil driver outputs. Avoid routing the low-power wiring parallel to the high power battery and motor cables.

## 35 PIN TABLE 1/2

PIN	NAME	DESCRIPTION
1	KSI	Key Switch Input signal, provides power to the controller and drivers
2	Horn Ground	Driver pin used to pull the reverse horn LO.
3	Not Used	
4	Brake Light	On some models, used for brake lights
5	Brake Coil -	Control driver for brake coil negative
6	Relay Coil -	Used to control the ground side of the Relay Coil.
7	Analog Ground	Ground Reference
8	Motor Temp	Temp Sensor input from motor to controller
9	Footswitch	Throttle Activation interlock switch
10	Tow/Run	Battery reference voltage from Tow/Run switch
11	Charger	Interlock signal from charging system.
12	Brake Switch	Engage/Disengaged microswitch on brake pedal
13	Key Switch	internally connected to pin 1
14	Not used	Not used
15	Throttle Power	5v reference for throttles
16	Throttle Wiper	Wiper connection of throttle input used for both resistive and voltage based throttles
17	Brake Wiper	Wiper connection for braking input



## 35 PIN TABLE 2/2

<b>PIN</b>	<b>NAME</b>	<b>DESCRIPTION</b>
18	Analog Ground	Ground signal used for throttle and brake sensor.
19	Not used	Not used
20	Not used	Not used
21	Not used	Not used
22	Forward	Forward direction input signal
23	Not used	Not used
24	Logic Power	Tied to keyswitch voltage with the RXV
25	12v	12v reference, used in some throttle applications
26	5v Tach	5v reference for speed sensor
27	Not Used	Not Used
28	Can Lo	Lo-side communication for CAN
29	Can Hi	Hi-side communication for CAN
30	Reserved	
31	Tach A	Used for Quadrature and Sin/Cos speed sensors
32	Tach B	Used for Quadrature and Sin/Cos speed sensors
33	Reverse	Reverse direction input signal
34	Digital Ground	Ground used for Tach/Speed Sensor
35	Tach C	Not used on the RXV

# WIRE HARNESS PINOUT

## 23 PIN AMP SEAL connector - RXV Danaher

The majority of low power connections will be made through the 23 pin amp seal connector. The pinouts are different on the 2008-2011 carts compared to newer ones and used a 23 pin connector with a Danaher Controller.

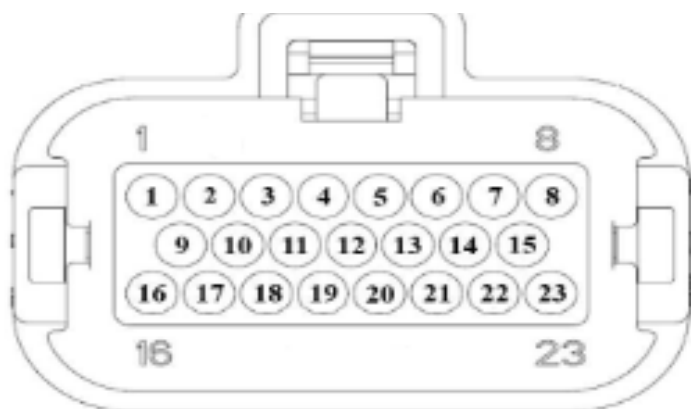

*The image shows the carts wire harness when unplugged and viewed from the rear - where the wires go into the connector itself.*

## 23 PIN TABLE 1/2

PIN	NAME	DESCRIPTION
1	Key in/Logic Power	Main battery reference for the low current system.
2	CAN interface	Digital ground for the CAN interface
3	5v reference	+5 volt to the speed sensor, brake sensor and throttle
4	Speed Sensor Lo	Common/Ground reference for the speed sensor
5	Tach A	Speed sensor quadrature A
6	Tach B	Speed sensor quadrature B
7	Brake Sensor Sig	Output signal from brake sensor
8	CAN Ground	Ground/Common reference for CAN BUS and speedo
9	Throttle Signal	Signal output wire of the throttle
10	Horn (Reverse)	Signal control wire for activating the reverse buzzer.
11	SOC out	State of charge output, usually not used on RXV

## 23 PIN TABLE 2/2

<b>PIN</b>	<b>NAME</b>	<b>DESCRIPTION</b>
12	Forward	Forward signal from direction switch
13	Tow/Run	Input voltage from the Tow/Run switch
14	Not Used	Not Used
15	CAN Lo	Lo side signal for CAN BUS
16	Motor Temp Hi	Hi side of motor temperature signal
17	Charge Interlock	Charge interlock control signal
18	Main Contactor out	Control voltage used to activate the main contactor
19	Footswitch	Voltage out of the footswitch to signal controller
20	Reverse	Reverse signal from direction switch
21	ACC	On some units goes to an accessory harness
22	Brake Light Relay	Control signal for brake light
23	Can Pos	Hi side CAN signal

# CONTROLLER DIMENSIONS

## TOP DOWN VIEW

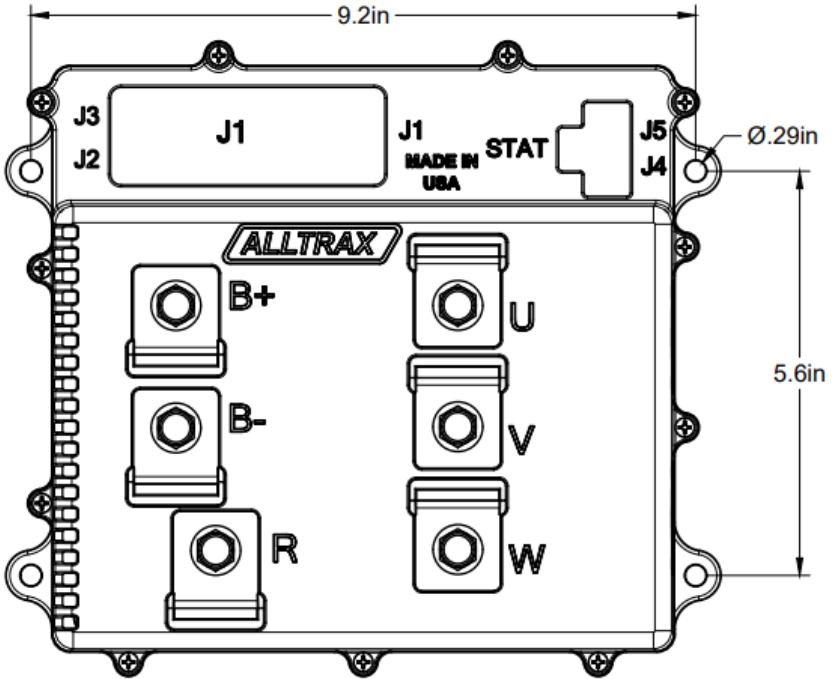

# CONTROLLER DIMENSIONS

## SIDE VIEW

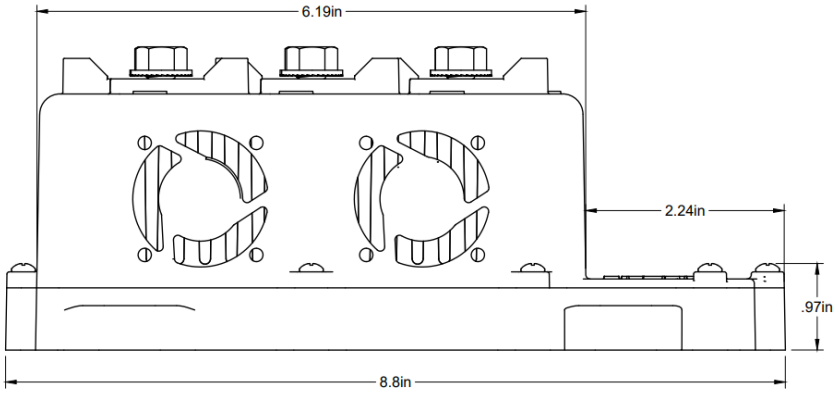

## FRONT VIEW

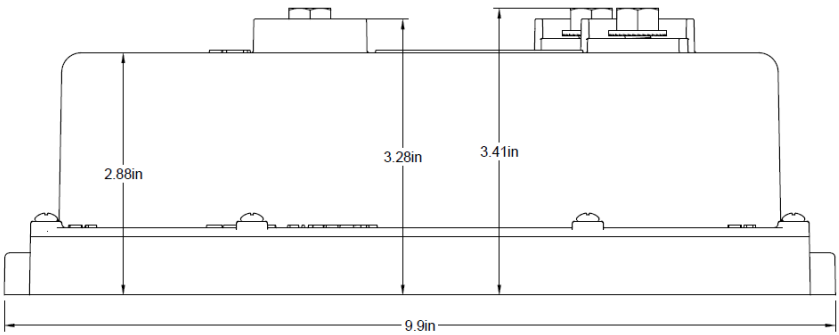

# **VEHICLE INSTALLATION DRAWINGS**

Don't see a drawing that suites your needs?  
Visit our website for full sized, updated and more drawings.  
[www.alltraxinc.com](http://www.alltraxinc.com)

# E-Z-GO RXV CURTIS

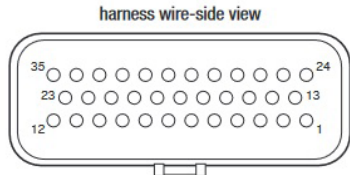
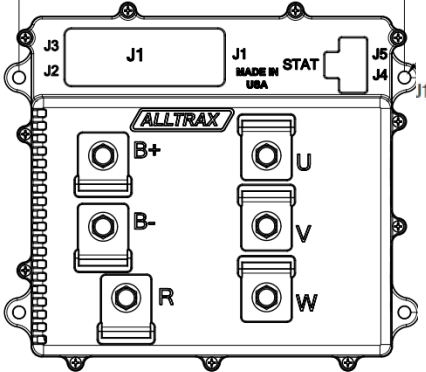

**J1** - For an indepth description of each wire on the harness see pages 18-20

- J1** - Main wire harness connector
- J2** - Personality Switch
- J3** - AC Motor case ground
- J4** - Can Bus
- J5** - Programming port (USB A)

- B+** Positive from Solenoid
- B-** Battery Negative
- R** Large resistor connection
- U** U of the Motor
- V** V of the Motor
- W** W of the Motor



# E-Z-GO RXV 35 SCHEMATIC

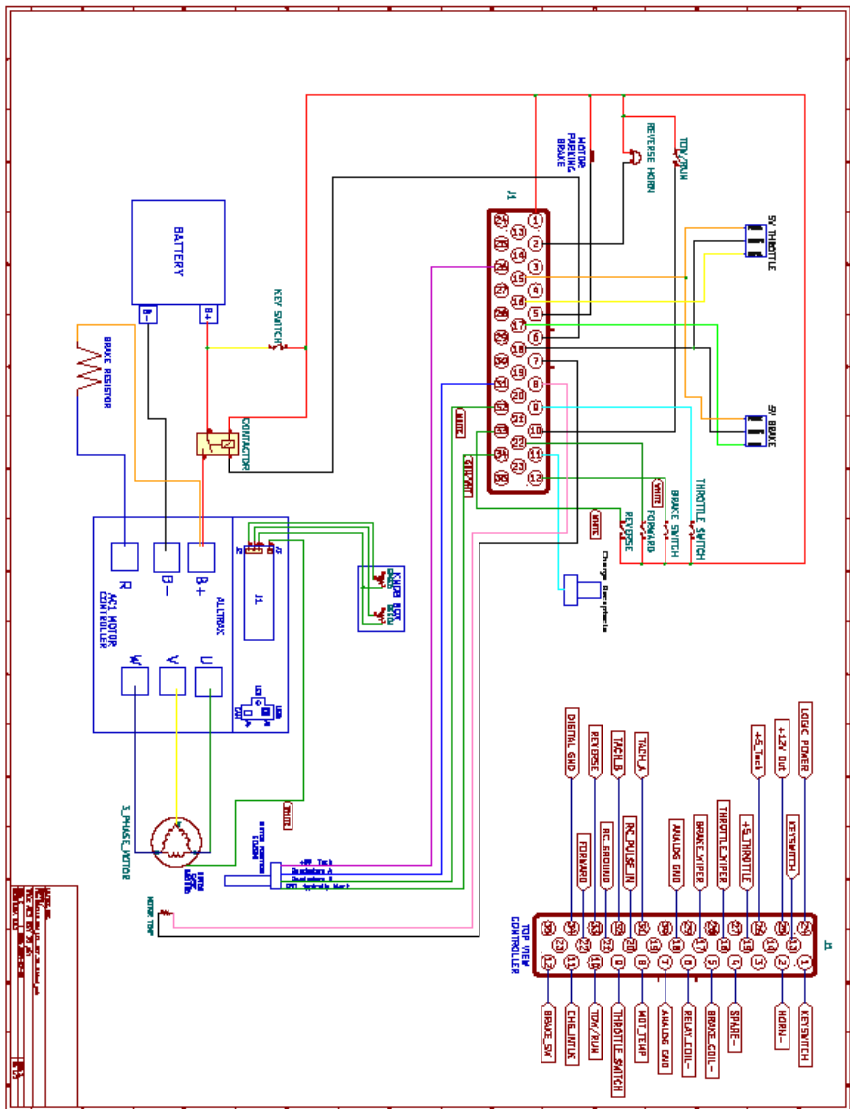

# E-Z-GO RXV DANAHER

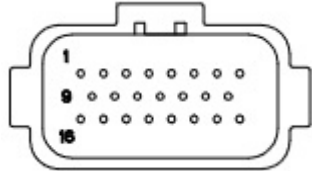
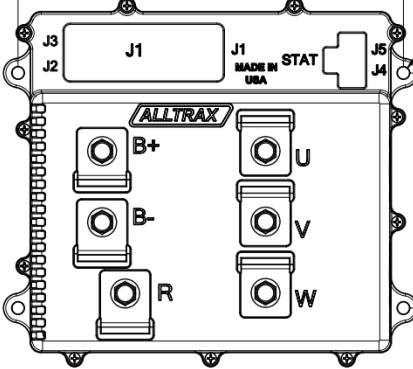

**J1**- For an indepth description of the wire harness see pages 24 - 26 of this manual.

- J1** - Main wire harness connector
- J2** - Personality Switch
- J3** - AC Motor case ground
- J4** - Can Bus
- J5** - Programming port (USB A)

- B+** Positive from Solenoid
- B-** Battery Negative
- R** Large resistor connection
- U** U of the Motor
- V** V of the Motor
- W** W of the Motor



# PROGRAMMING THE CONTROLLER

Controllers ordered for stock configuration come pre-programmed and do not need to be programmed before use. If the user would like to customize their performance or has upgraded their motor and needs a matching motor map the controller can be connected to a computer with a USB A to B, commonly referred to as a “printer cable”.



The USB A to B cable is used to connect your motor controller to your personal computer. Using the free Alltrax Toolkit you can customize your performance to match your needs.

The Alltrax Toolkit software can be downloaded from:  
<https://alltraxinc.com/alltrax-tool-kit/>  
No purchase necessary

[DOWNLOAD SOFTWARE](#)

**Alltrax Toolkit Software Manual**

[DOWNLOAD MANUAL](#)

# BLINK CODES

---

On power up, the controller will blink out a throttle code and then a Status or Error Code (see below)

## Throttle Type Codes:

1 Green LED Flash	=	2-wire 0-5k throttle
2 Green LED Flash	=	2-wire 5K-0 throttle
3 Green LED Flash	=	0-5V throttle
4 Green LED Flash	=	EZGO ITS throttle
5 Green LED Flash	=	3-wire 0-5k
6 Green LED Flash	=	6 to 10.5 Taylor Dunn throttle
7 Green LED Flash	=	MCOR
8 Green LED Flash	=	Reserved
9 Green LED Flash	=	Pump
10 Green LED Flash	=	USB Throttle
11 Green LED Flash	=	Absolute Throttle
12 Green LED Flash	=	PWM_Throttle

## Brake Type Codes:

1 Green LED Flash	=	2-wire 0-5k throttle
2 Green LED Flash	=	2-wire 5K-0 throttle
3 Green LED Flash	=	0-5V throttle
4 Green LED Flash	=	Reserved
5 Green LED Flash	=	3-wire 0-5k
6 Green LED Flash	=	6 to 10.5 Taylor Dunn throttle
7 Green LED Flash	=	MCOR
8 Green LED Flash	=	Reserved
9 Green LED Flash	=	Reserved
10 Green LED Flash	=	USB Throttle
11 Green LED Flash	=	Absolute Throttle

# BLINK CODES

## Normal Display Status:

Solid Green Light	=	Controller Ready to Run
Solid Red Light	=	Controller in programming mode
Solid Yellow Light	=	Throttle is wide open and the controller is <u>NOT</u> in Current Limit
Blinking Yellow Light	=	Throttle is wide open, but the controller is in Current Limit

## Error Codes:

AC alarm codes flash a sequence of green then red. All alarms are self clearing and will repeat until the error condition has been corrected.

1 Green and 1 Red LED Flash	=	Short Circuit/Output Fault
1 Green and 2 Red LED Flash	=	Battery Under Voltage
1 Green and 3 Red LED Flash	=	Battery Over Voltage
1 Green and 4 Red LED Flash	=	Over temperature
1 Green and 5 Red LED Flash	=	Throttle Power Fault
1 Green and 6 Red LED Flash	=	Pre-Charge Failure

2 Green and 1 Red LED Flash	=	Throttle/Brake Range
2 Green and 2 Red LED Flash	=	Bad Variables
2 Green and 3 Red LED Flash	=	High Throttle Over range
2 Green and 4 Red LED Flash	=	High Throttle Under range
2 Green and 5 Red LED Flash	=	Low Throttle Over range
2 Green and 6 Red LED Flash	=	Low Throttle Under range

3 Green and 1 Red LED Flash	=	Throttle/Brake Range
3 Green and 2 Red LED Flash	=	Bad Variable Set Loaded
3 Green and 3 Red LED Flash	=	Relay Coil Overcurrent
3 Green and 4 Red LED Flash	=	Brake Coil Overcurrent
3 Green and 5 Red LED Flash	=	Reserved Overcurrent*
3 Green and 6 Red LED Flash	=	Horn Overcurrent

4 Green and 1 Red LED Flash	=	Reserved
4 Green and 2 Red LED Flash	=	Reserved
4 Green and 3 Red LED Flash	=	Hardware Failure
4 Green and 4 Red LED Flash	=	Startup Failure
4 Green and 5 Red LED Flash	=	Reserved
4 Green and 6 Red LED Flash	=	Reserved

5 Green and 1 Red LED Flash	=	General Error
-----------------------------	---	---------------

# CODE DEFINITIONS

## Error Code Definitions:

- Short Circuit/Output Fault:  
Controller detected a short circuit or other fault on the output circuit.  
Check wiring.
- Battery Under Voltage:  
B+ Voltage lower than Low Voltage Battery Setting. Check pack voltage or program settings.
- Battery Over Voltage:  
B+ Voltage Higher than Over Voltage Battery Setting. Check pack voltage or program settings
- Over temperature:  
Busbar temperature exceeds 90°C. Let controller cool and/or add fan.
- Throttle power Fault:  
This is a 5V fault, if the speed sensor gets damaged this alarm will be one of the alarms triggered. Can also be caused by a fault in voltage based throttles
- Pre-charge Failure:  
B+ voltage and KSI voltage differ by more than 5v. Stuck solenoid.
- Under Temp:  
Busbar Temperature reads less than -20°C
- High Throttle Over range & High Throttle Under range:  
High Side of throttle signal is outside of acceptable window for that throttle type. Check and/or replace throttle. Change throttle type to correct throttle installed on car.
- Low Throttle Over range & Low Throttle Under range:  
Low Side of throttle signal is outside of acceptable window for that throttle type. Check and/or replace throttle. Change throttle type to correct throttle installed on car.
- Bad Variable Set Loaded:  
Alltrax loaded variable data is missing or corrupted. Contact Alltrax
- Throttle/Brake Range:  
The RXV has a “throttle” built into the brake pedal to communicate with the motor brake. This alarm indicates an error in that signal.

# CODE DEFINITIONS

## **Error Code Definitions:**

- Relay coil overcurrent:  
Relay coil has shorted, the wires were attached incorrectly or the suppression control diode is backwards.
  
- Brake coil overcurrent:  
Short in the brake pedals resistor coil. Presently this can only trigger on EZGO RXV applications
  
- Horn Overcurrent:  
There is a short in the horn circuit, could be wiring or horn related
  
- Startup Failure:  
The RXV runs through a sequence of system checks before allowing vehicle operation:
  - 1) Check to make sure you're parked
  - 2) Test Horn
  - 3) Pull in contactor
  - 4) Apply phase amps (you will feel the motor "bump")
  - 5) Turn off phase, disengage brake, check for currentIf any of these 5 steps fails the RXV will refuse to operate.



# WARRANTY STATEMENT

---

Alltrax, Inc., (hereafter Alltrax) warrants that the product purchased is free from defects in materials or workmanship for a period of 2 years from the date of manufacture. This warranty does not apply to defects due directly or indirectly to misuse, abuse, negligence, accidents, repairs, improper installation, submersion, alterations or use contrary to any instructions provided by Alltrax in verbal or written form.

In the event you should need warranty repair, contact Alltrax at (541) 476-3565 to receive warranty service authorization instructions for returning the defective product to Alltrax for evaluation. Products or parts shipped by customer to Alltrax must be sent postage paid and packaged appropriately for safe shipment. Alltrax is not responsible for customer products received without warranty service authorization and may be rejected.

Alltrax reserves the right to repair or replace merchandise at its option at no cost to the customer, except for shipping costs of sending the defect item to Alltrax. Replacement shall mean furnishing the customer with a new equivalent product to the defective item. Alltrax also reserves the right to make changes to any of its products or specifications without notice.

Alltrax assumes no liability for applications assistance or customer product design. Customers shall be responsible for evaluating the appropriateness of the use of any Alltrax product in any application. Customers shall provide adequate design and operating safeguards that are in compliance with standard practices of other similar applications or any standards of any governing agency.

**THIS IS ALLTRAX INC.'S, SOLE WARRANTY.**

**NO REPRESENTATIVE EMPLOYEE, DISTRIBUTOR OR DEALER OF ALLTRAX HAS THE AUTHORITY TO MAKE OR IMPLY ANY WARRANTY, REPRESENTATION, PROMISE OR AGREEMENT, WHICH IN ANY WAY VARIES THE TERMS OF THIS LIMITED WARRANTY.**

**ALLTRAX PRODUCTS SOLD TO CUSTOMER ARE INTENDED TO BE USED ONLY IN THE APPLICATION SPECIFIED BY THE CUSTOMER TO ALLTRAX. ANY OTHER USE RENDERS THE LIMITED WARRANTY EXPRESSED HEREIN AND ALL IMPLIED WARRANTIES NULL AND VOID AND SAME ARE HEREBY EXCLUDED.**

## **DISCLAIMER OF IMPLIED WARRANTIES**

**ALLTRAX, INC., SHALL IN NO EVENT BE LIABLE FOR DEATH, INJURIES TO PERSONS OR PROPERTY, OR FOR INCIDENTAL, CONTINGENT, OR CONSEQUENTIAL DAMAGES ARISING FROM THE USE OR MISUSE OF OUR PRODUCTS.**

**EXCEPT SPECIFICALLY PROVIDED HEREIN, THERE ARE NO OTHER WARRANTIES, EXPRESS OR IMPLIED, INCLUDING, BUT NOT LIMITED TO, ANY IMPLIED WARRANTIES OF MERCHANTABILITY OR FITNESS FOR A PARTICULAR PURPOSE. HOWEVER, SOME STATES DO NOT ALLOW LIMITATIONS ON HOW LONG AN IMPLIED WARRANTY LASTS, SO THE PRECEDING EXCLUSION MAY NOT APPLY TO YOU.**

*“Thank you Nikola Tesla, for a better motor”*