

# NAVITAS

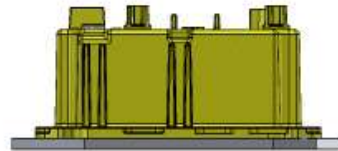
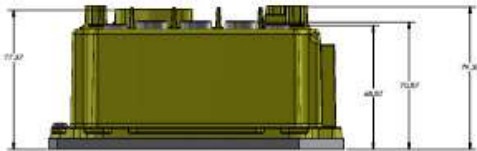
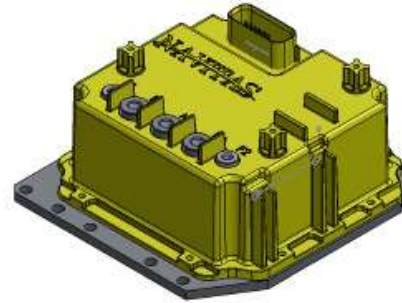
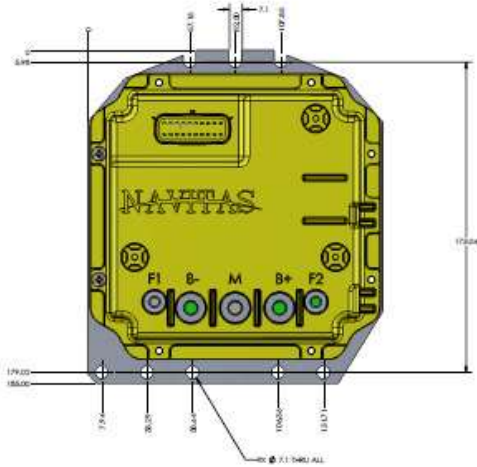

- Base footprint 165x185mm
- Enclosure height 79.37mm (connector housing [without plug] projects a further 17mm)
- Field connection is 2xM5 bolt
- Motor and battery connection are 3xM8 bolt
- Connectors are Molex 20 pin MX150
- Ingress: Robust ABS/aluminum enclosure designed to meet IP67.
- Operating Ambient Temperature: -40°C to +55°C
- Storage Temperature: -40°C to +70°C
- Switching frequency: 16 kHz