

A2	A1			
F2	F1			
Mfg. Date	Serial #	Rating	Class H	Voltage
				36
MADE IN U.S.A.				

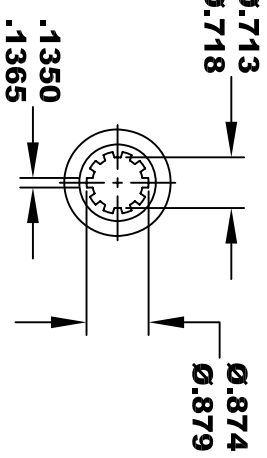

**10 TOOTH
INTERNAL SPLINE
HARDNESS OF SPLINE
TO BE R/C 46 - 53 (.02 DEPTH MIN)**

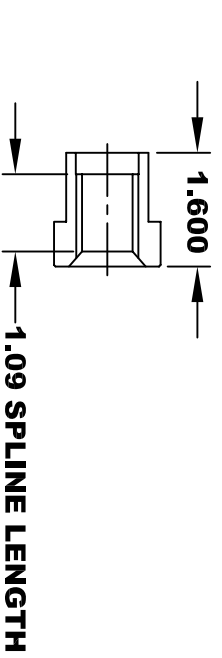
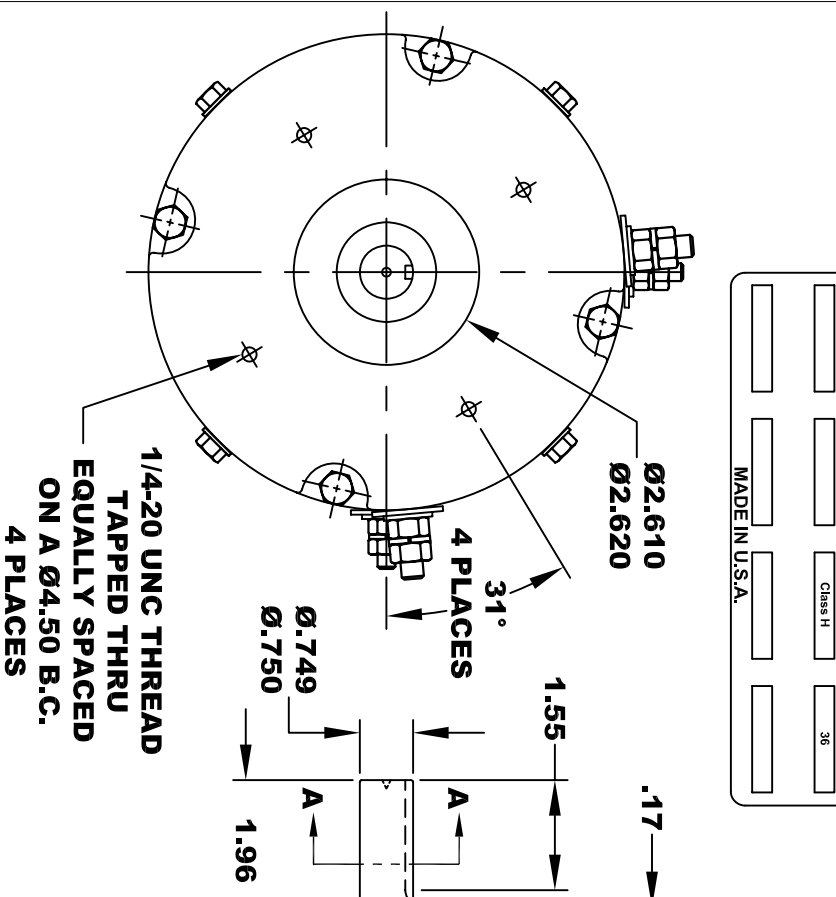
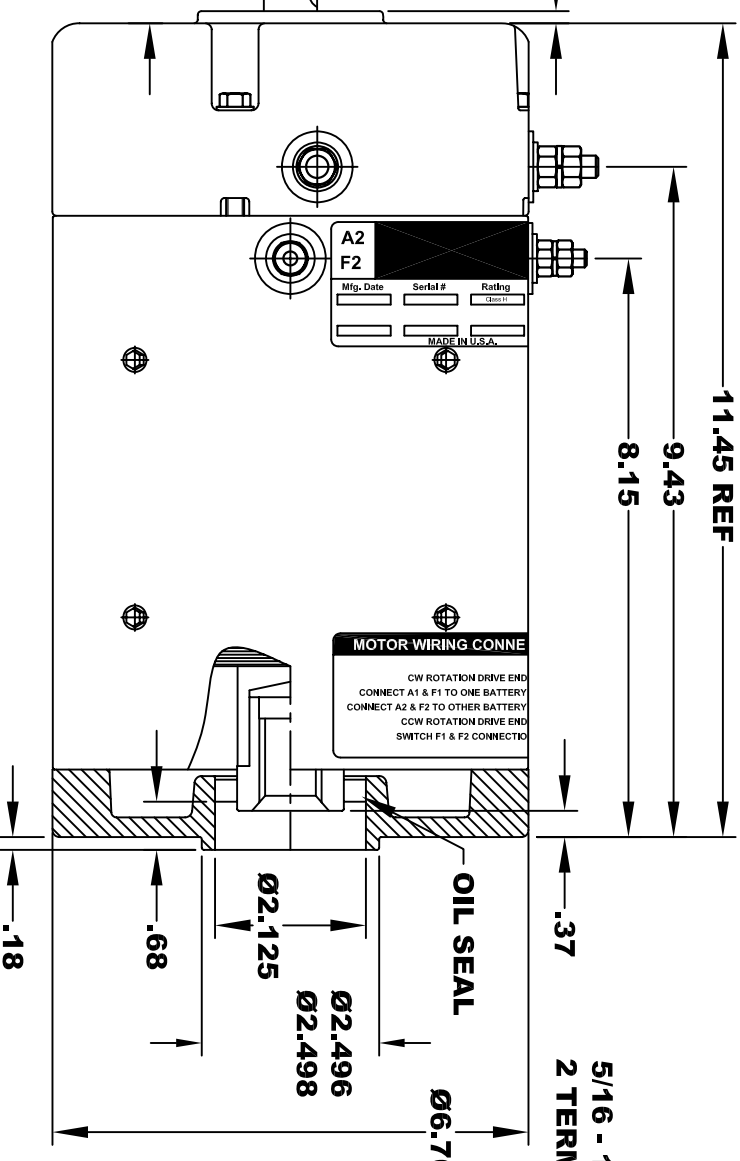
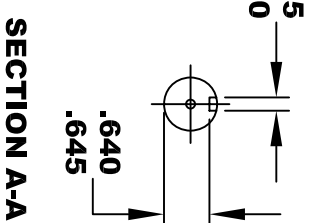

**TORQUE SPECIFICATION FOR
POWER CABLE SECURING TOP NUTS
5/16-18 UNC (A1 / A2) - 110 IN / LBS MAX
1/4-20 UNC (F1 / F2) - 50 IN / LBS MAX**

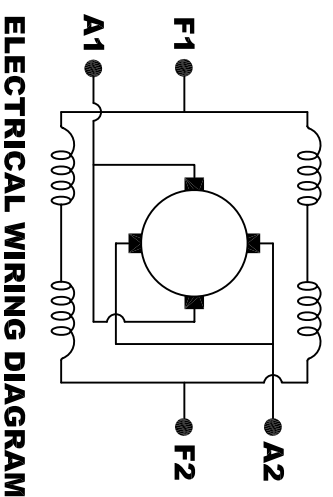

**MOTOR WIRING CONNECTIONS:
CW ROTATION DRIVE END
CONNECT A1 & F1 TO ONE BATTERY TERMINAL
CONNECT A2 & F2 TO OTHER BATTERY TERMINAL
CCW ROTATION DRIVE END
SWITCH F1 & F2 CONNECTIONS**

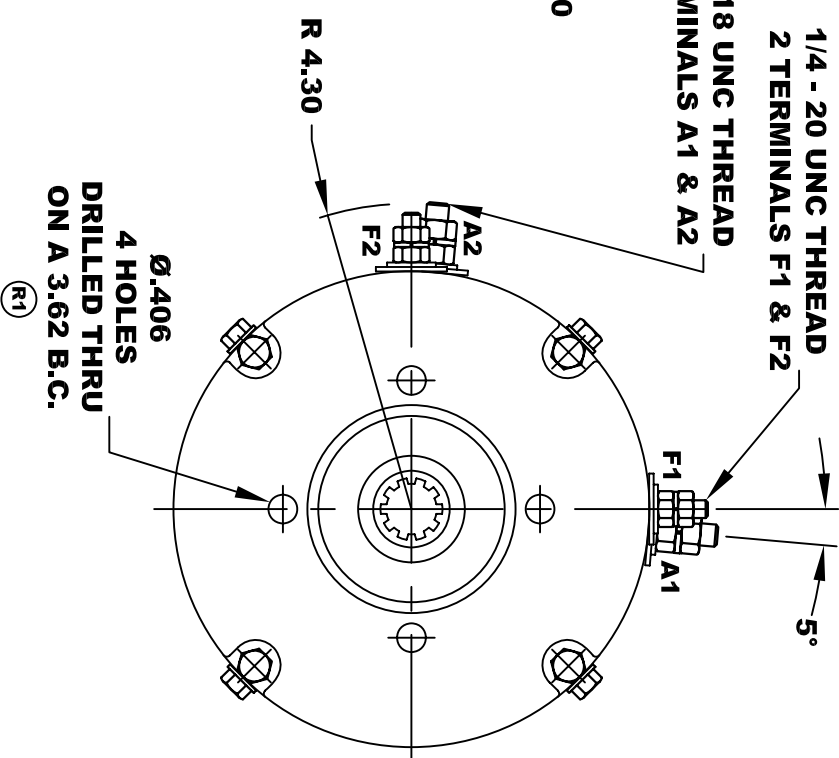

DRAFT

**MOTOR WEIGHT: 57 LBS
CLASS "H" INSULATION
PERFORMANCE SPEC: 8**

D & D MOTOR SYSTEMS INC

MOTOR OUTLINE

THIS PRINT IS THE PROPERTY OF D&D MOTOR SYSTEMS INC.
DO NOT SCALE
WORK TO DIMENSIONS
TOLERANCES UNLESS OTHERWISE SPECIFIED ARE AS FOLLOWS
.XX _____ .01
.XXX _____ .005
.XX ROUGH CASTING _____ .03
HOLES _____ -.001 / +.006
ANGLES _____ 0°30"

SIZE	DRAWN DATE	RELEASE DATE	DWG NO. / PART NO.	REV
SCALE	2-1-07		170-503 GEAR TECH	R1
	STF	DRAWN BY	MJG	REV DATE
				2-20-07