

D&D MOTOR SYSTEMS INC.			
SYRACUSE N.Y.			
A2	A1		
F2	F1		
Model # 170 - 513 - 0002			
Mfg. Date	Serial #	Rating	Voltage
XXXXXX	XXXX	CLASS - H	36 / 48
MADE IN U.S.A.			

**TORQUE SPECIFICATION FOR
POWER CABLE SECURING TOP NUTS**
5/16-18 UNC (A1 / A2) - 110 IN / LBS MAX
1/4-20 UNC (F1 / F2) - 50 IN / LBS MAX

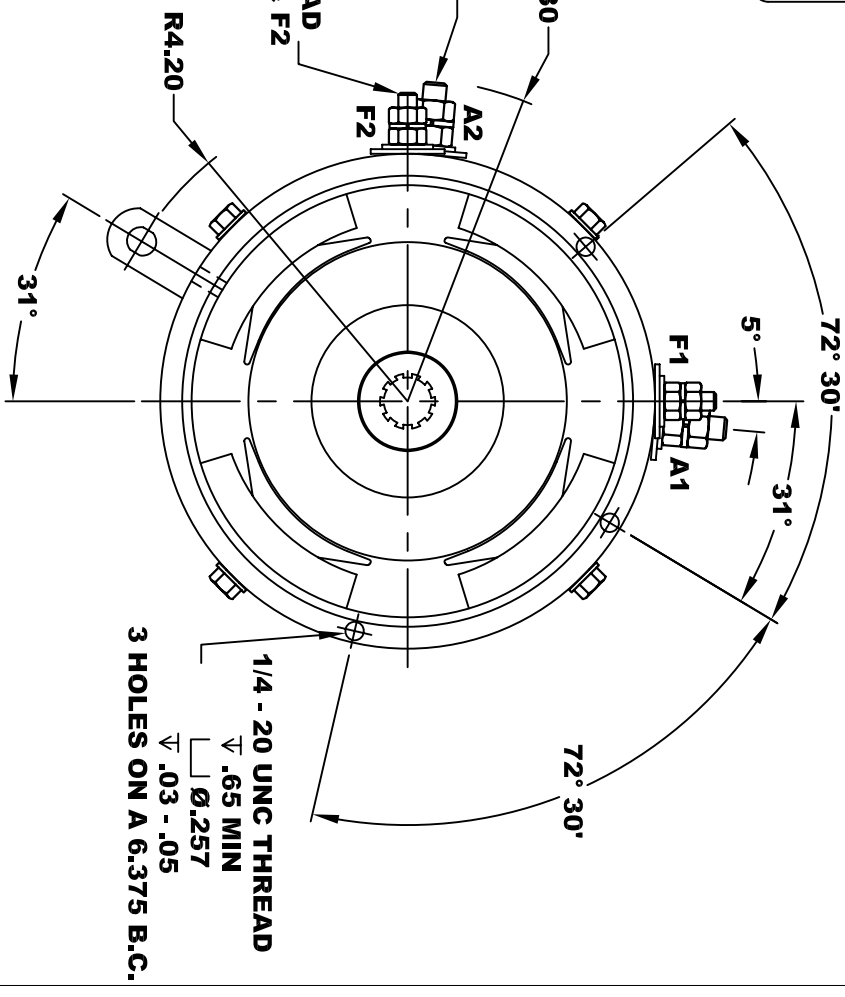

ELECTRICAL SPECIFICATION:
-4.5V TO 24V OPERATING VOLTAGE
-20°C TO 85°C OPERATING TEMPERATURE
-CURRENT SINKING UP TO 25mA
-AN EXTERNAL OUTPUT PULL UP RESISTOR IS REQUIRED
-SENSOR IS DESIGNED TO OPERATE WITH 4 N/S POLEPAIRS
-THE OPERATIONAL DISTANCE BETWEEN THE MAGNET
-AND THE HOUSING, INCLUDING ANY RUNOUT
-SHOULD NOT EXCEED .030 INCHES

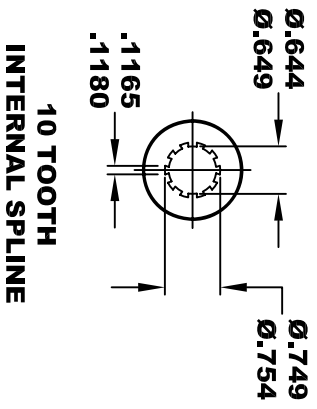
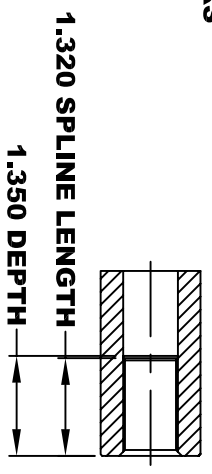
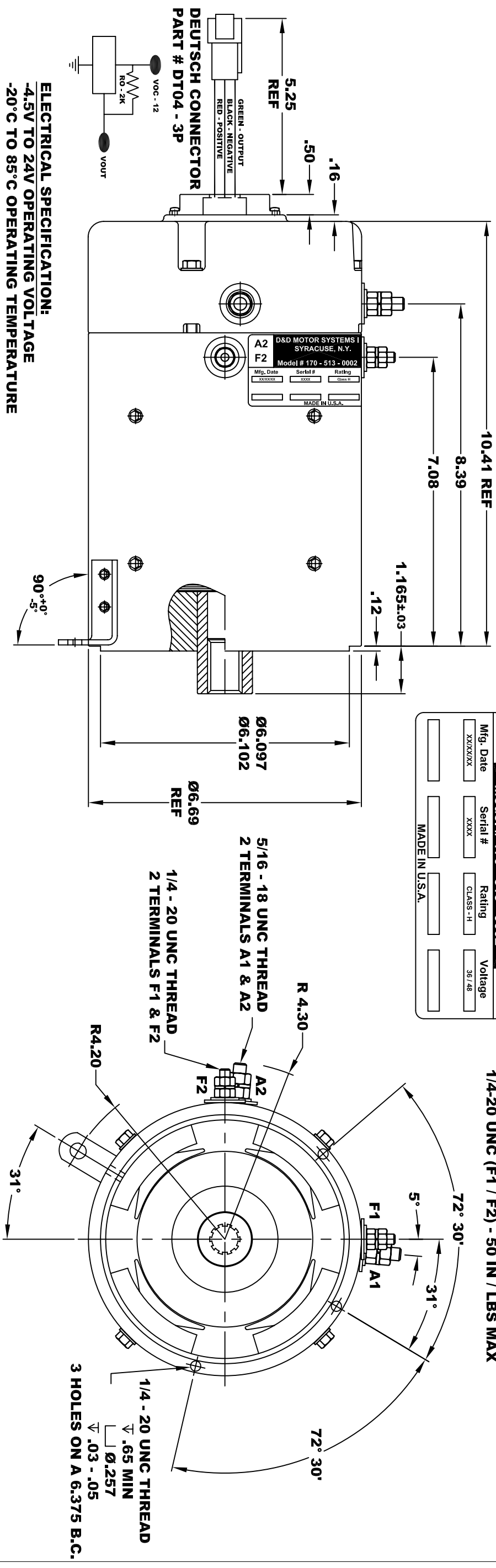
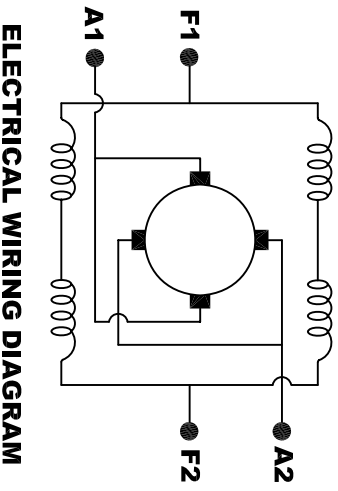
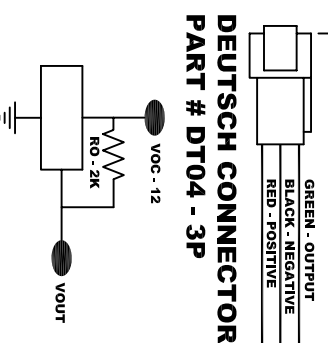

MOTOR WIRING CONNECTIONS:
CW ROTATION DRIVE END
CONNECT A1 & F1 TO ONE BATTERY TERMINAL
CONNECT A2 & F2 TO OTHER BATTERY TERMINAL
CCW ROTATION DRIVE END
SWITCH F1 & F2 CONNECTIONS

MOTOR WEIGHT 57 LBS
CLASS "H" INSULATION
PERFORMANCE SPEC: 50

THIS PRINT IS THE PROPERTY OF D&D MOTOR SYSTEMS INC.
DO NOT SCALE
WORK TO DIMENSIONS
TOLERANCES UNLESS OTHERWISE SPECIFIED ARE AS FOLLOWS
.XX _____ .01
.XXX _____ .005
.XX ROUGH CASTING _____ .03
HOLES _____ -.001 / +.006
ANGLES _____ 0°30"

D & D MOTOR SYSTEMS INC			
MOTOR OUTLINE			
SIZE	DRAWN DATE	RELEASE DATE	DWG NO. / PART NO.
B	4-13-04	7-15-08	170 - 513 - 0002
SCALE	STF	DRAWN BY	REV DATE
		MJG	ES-9C-50