

<b>D&amp;D MOTOR SYSTEMS INC.</b>			
SYRACUSE N.Y.			
<b>A2</b>	<b>A1</b>	<b>F1</b>	<b>F2</b>
Model # ES-107B-7			
Mfg. Date	Serial #	Rating	Voltage
XXXXXX	XXXX	CLASS-H	XX
MADE IN U.S.A.			

**TORQUE SPECIFICATION FOR POWER CABLE SECURING TOP NUTS**  
 3/8-16 UNC (A1 / A2) - 140 IN / LBS MAX  
 1/4-20 UNC (F1 / F2) - 50 IN / LBS MAX

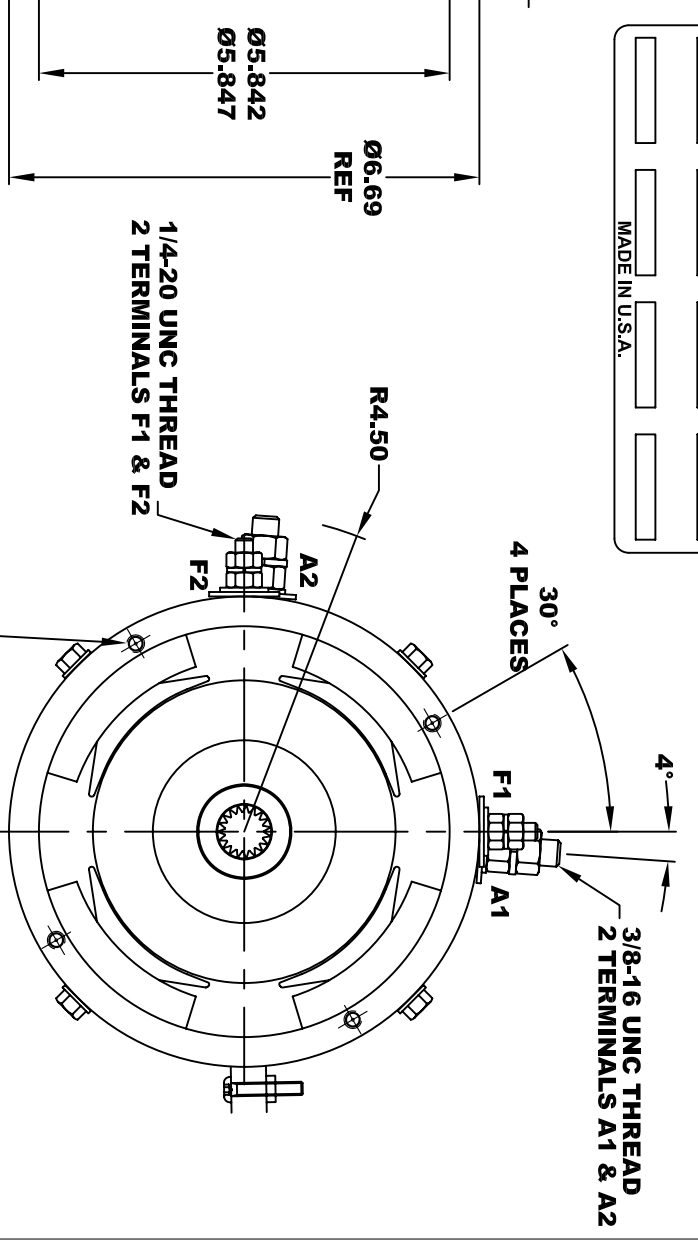
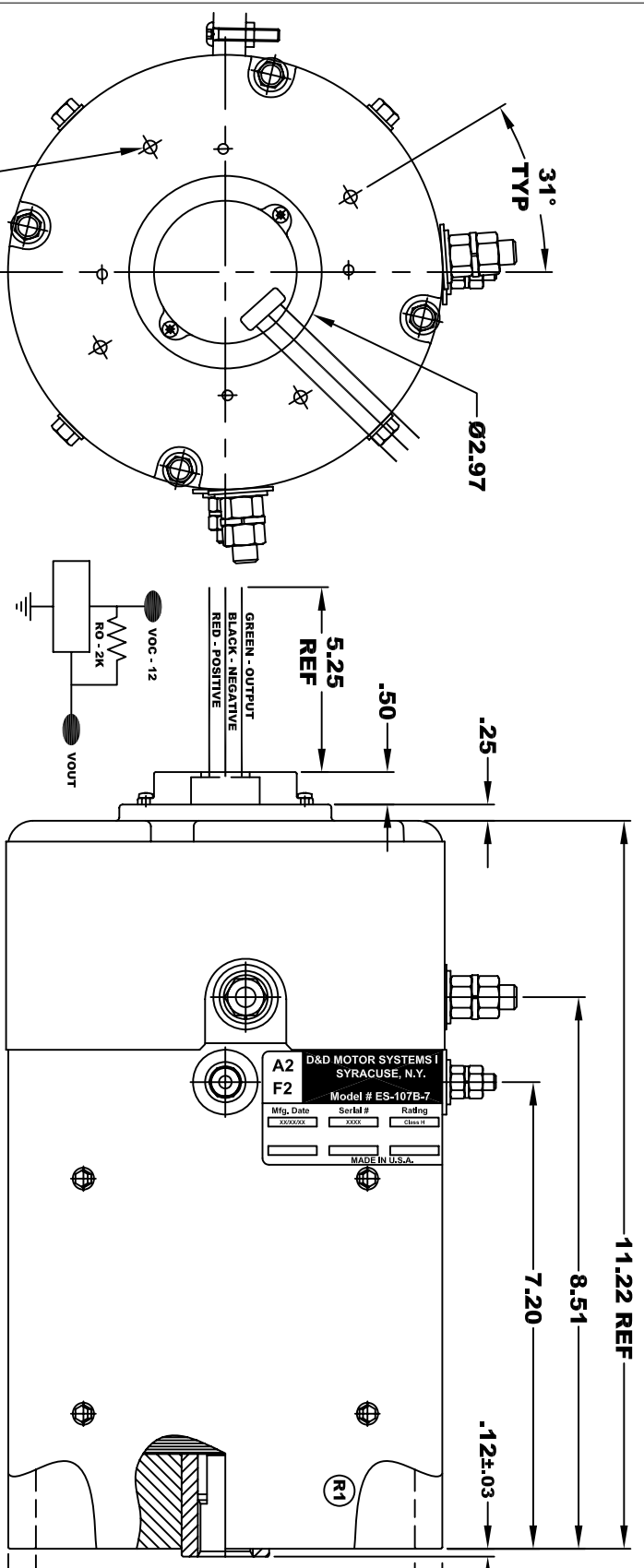

1/4-20 UNC THREAD  
 TAPPED THRU  
 EQUALLY SPACED  
 ON A Ø4.50 B.C.  
 4 PLACES

**ELECTRICAL SPECIFICATION:**  
 -4.5V TO 24V OPERATING VOLTAGE  
 -20°C TO 85°C OPERATING TEMPERATURE  
 -CURRENT SINKING UP TO 25mA  
 -AN EXTERNAL OUTPUT PULL UP RESISTOR IS REQUIRED  
 -SENSOR IS DESIGNED TO OPERATE WITH 4 N/S POLEPAIRS  
 THE OPERATIONAL DISTANCE BETWEEN THE MAGNET  
 AND THE HOUSING, INCLUDING ANY RUNOUT  
 SHOULD NOT EXCEED .030 INCHES

**INTERNAL INVOLUTE SPLINE SPECIFICATION**  
 CLASS 5 FILLET ROOT SIDE FIT (PER A.N.S.I. B92.1)

NO. OF TEETH	19
SPLINE PITCH	24 / 48
PRESSURE ANGLE	45°
BASE Ø	.5597 REF
PITCH Ø	.7916 REF
MAJOR Ø	.850 - .859
FORM Ø	.835
MINOR Ø	.767 - .772
CIRCULAR SPACE WIDTH	.0764
EFFECTIVE SPACE WIDTH	.0738
MAX. DIMENSION BETWEEN TWO PINS	.6714
PIN Ø	.0800
SPLINE HARDNESS TO BE R/C	26-34

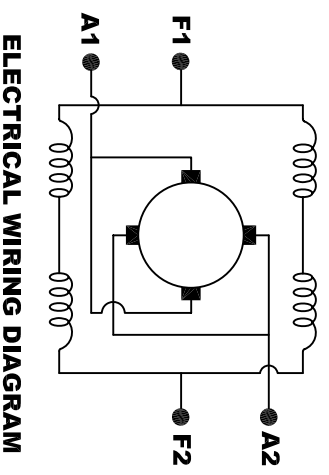
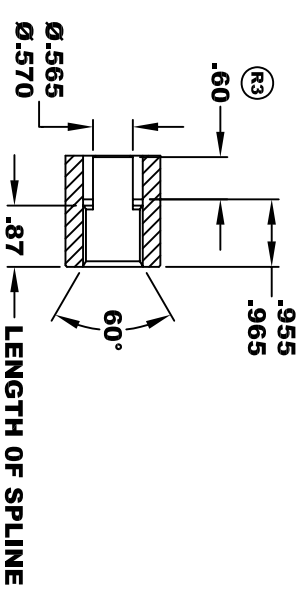

**MOTOR WIRING CONNECTIONS:**  
 CW ROTATION DRIVE END  
 CONNECT A1 & F1 TO ONE BATTERY TERMINAL  
 CONNECT A2 & F2 TO OTHER BATTERY TERMINAL  
 CCW ROTATION DRIVE END  
 SWITCH F1 & F2 CONNECTIONS

MOTOR WEIGHT 62 LBS (R2)  
 CLASS "H" INSULATION  
 PERFORMANCE SPEC: 7

THIS PRINT IS THE PROPERTY OF D&D MOTOR SYSTEMS INC.  
 DO NOT SCALE  
 WORK TO DIMENSIONS  
 TOLERANCES UNLESS OTHERWISE SPECIFIED ARE AS FOLLOWS  
 .XX \_\_\_\_\_ .01  
 .XXX \_\_\_\_\_ .005  
 .XX ROUGH CASTING \_\_\_\_\_ .03  
 HOLES \_\_\_\_\_ ±.001 / +.006  
 ANGLES \_\_\_\_\_ 0°30"

**D & D MOTOR SYSTEMS INC**

**MOTOR OUTLINE**

SIZE	DRAWN DATE	RELEASE DATE	DWG NO. / PART NO.	REV
B	11-17-06		ES-107B-7	R3
SCALE	STF	DRAWN BY	MJG	REV DATE
				3-16-16