

D&D MOTOR SYSTEMS INC.			
A2		A1	
SYRACUSE N.Y.			
Model # ES-10G-5			
Mfg. Date	Serial #	Rating	Voltage
XX/XX/XX	XXXX	CLASS H	XX
MADE IN U.S.A.			

**TORQUE SPECIFICATION FOR
POWER CABLE SECURING TOP NUTS**
5/16-18 UNC (A1 / A2) - 110 IN / LBS MAX
1/4-20 UNC (F1 / F2) - 50 IN / LBS MAX

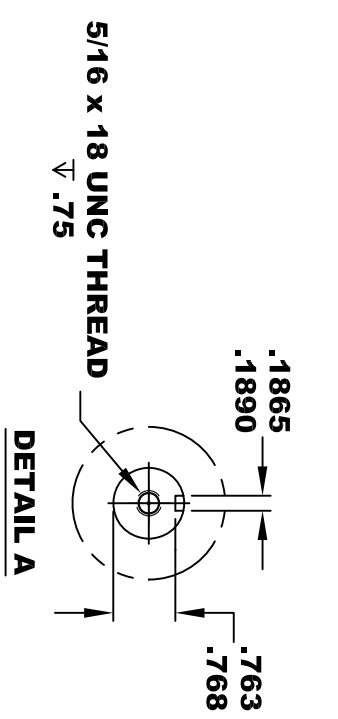

3/8 - 16 UNC THREAD
↓ .65 MINIMUM
.03 -.05 X 45° CHAMFER
4 PLACES, ON A Ø5.875 B. C.

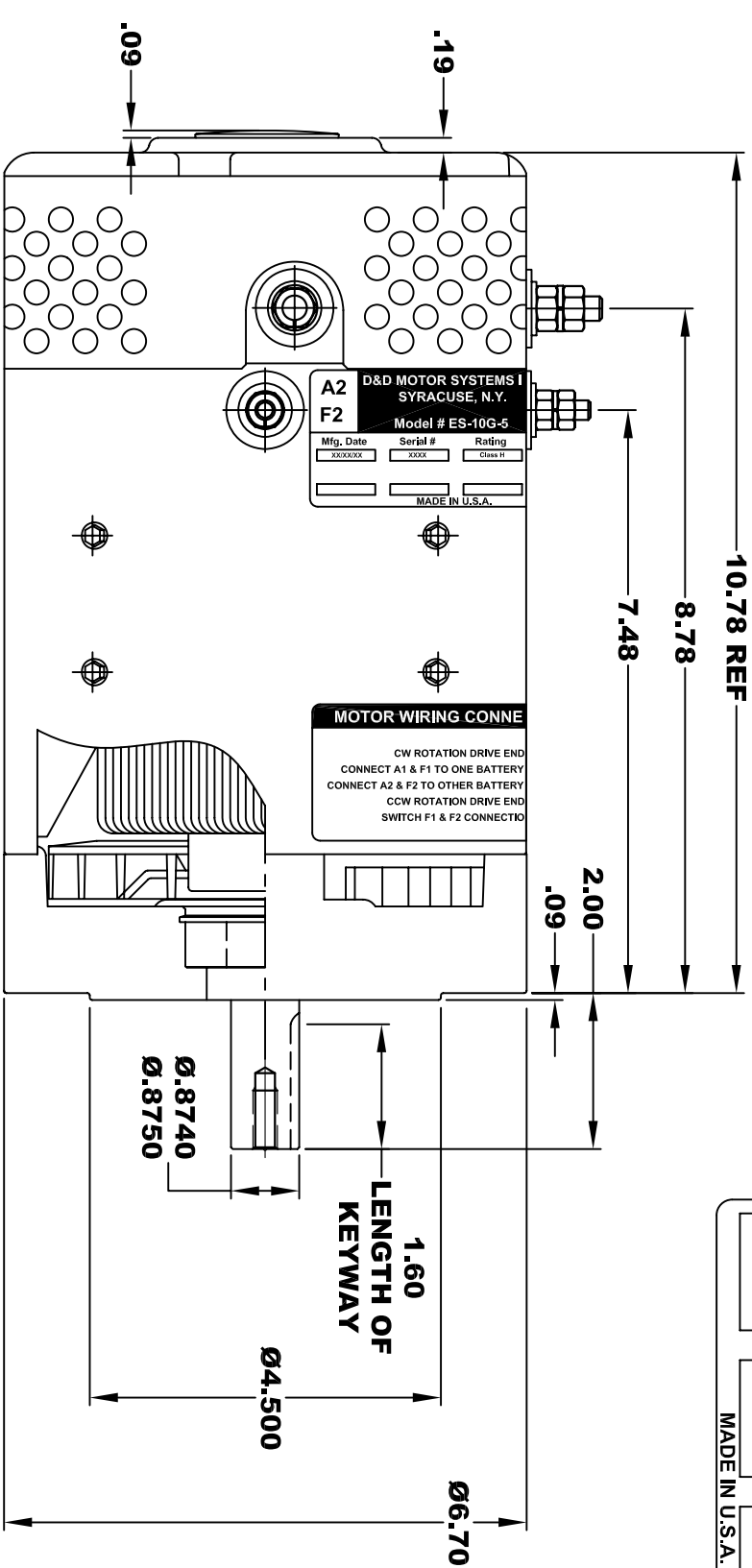
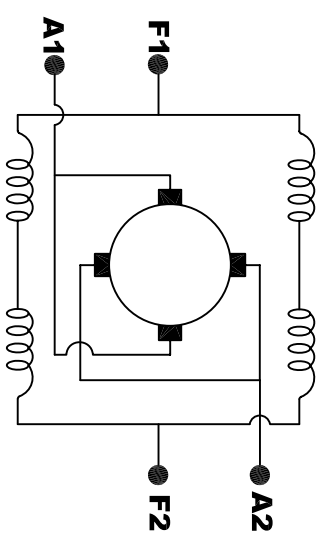
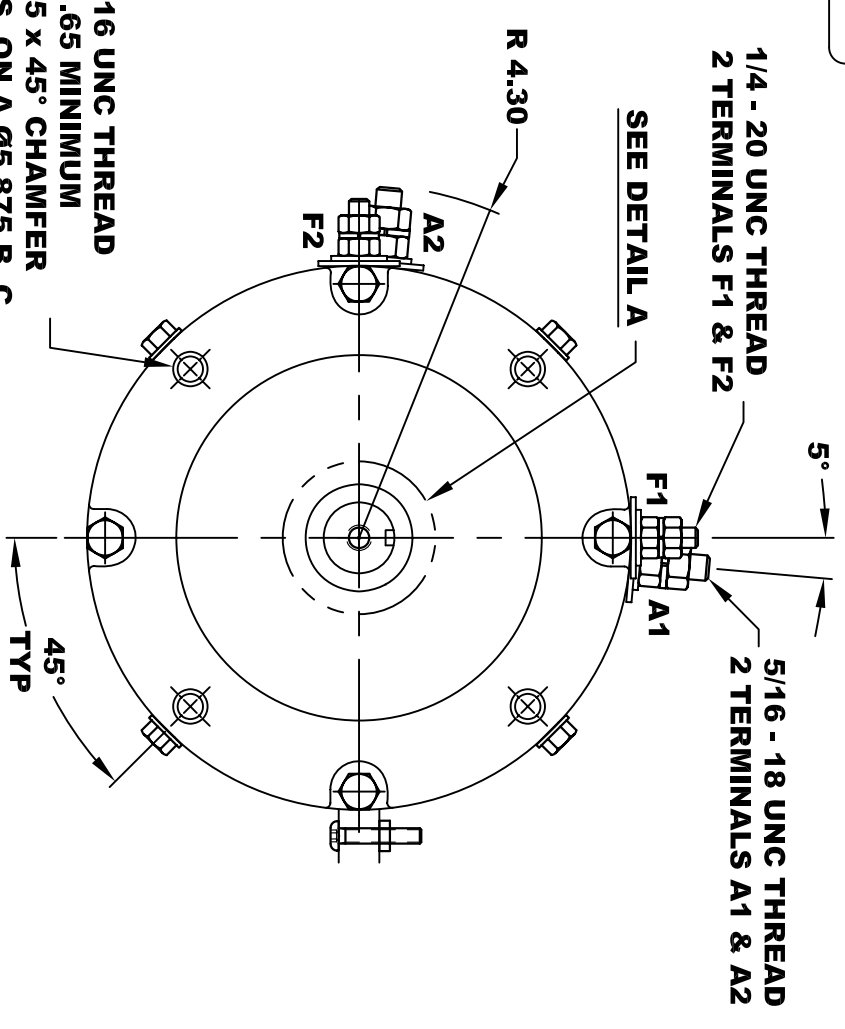

ELECTRICAL WIRING DIAGRAM

MOTOR WIRING CONNECTIONS:
CW ROTATION DRIVE END
CONNECT A1 & F1 TO ONE BATTERY TERMINAL
CONNECT A2 & F2 TO OTHER BATTERY TERMINAL
CCW ROTATION DRIVE END
SWITCH F1 & F2 CONNECTIONS

THIS PRINT IS THE PROPERTY OF D&D MOTOR SYSTEMS INC.
 DO NOT SCALE
 WORK TO DIMENSIONS
 TOLERANCES UNLESS OTHERWISE SPECIFIED ARE AS FOLLOWS

.XX	.01
.XXX	.005
.XX ROUGH CASTING	.03
HOLES	-.001 / +.006
ANGLES	0°30"

MOTOR WEIGHT: 50 LBS
CLASS "H" INSULATION
PERFORMANCE SPEC: 5

D & D MOTOR SYSTEMS INC

MOTOR OUTLINE

SIZE	DRAWN DATE	RELEASE DATE	DWG NO. / PART NO.	REV
B	11-28-05		ES-10G-5	
SCALE	STF	DRAWN BY	MJG	REV DATE