

**TORQUE SPECIFICATION FOR  
POWER CABLE SECURING TOP NUTS  
5/16-18 UNC - 110 IN / LBS MAX**

<b>D&amp;D MOTOR SYSTEMS INC.</b>			
<b>A2</b>		<b>A1</b>	
<b>SYRACUSE N.Y.</b>			
<b>Model # ES-110-11</b>			
Mfg. Date	Serial #	Rating	Voltage
XXXXXX	XXXX	Class H	XX
MADE IN U.S.A.			

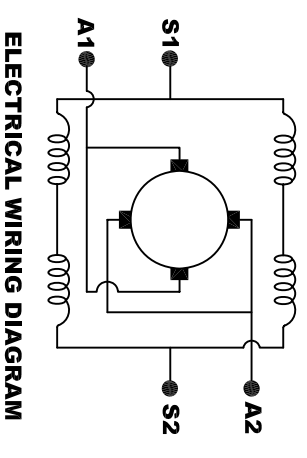
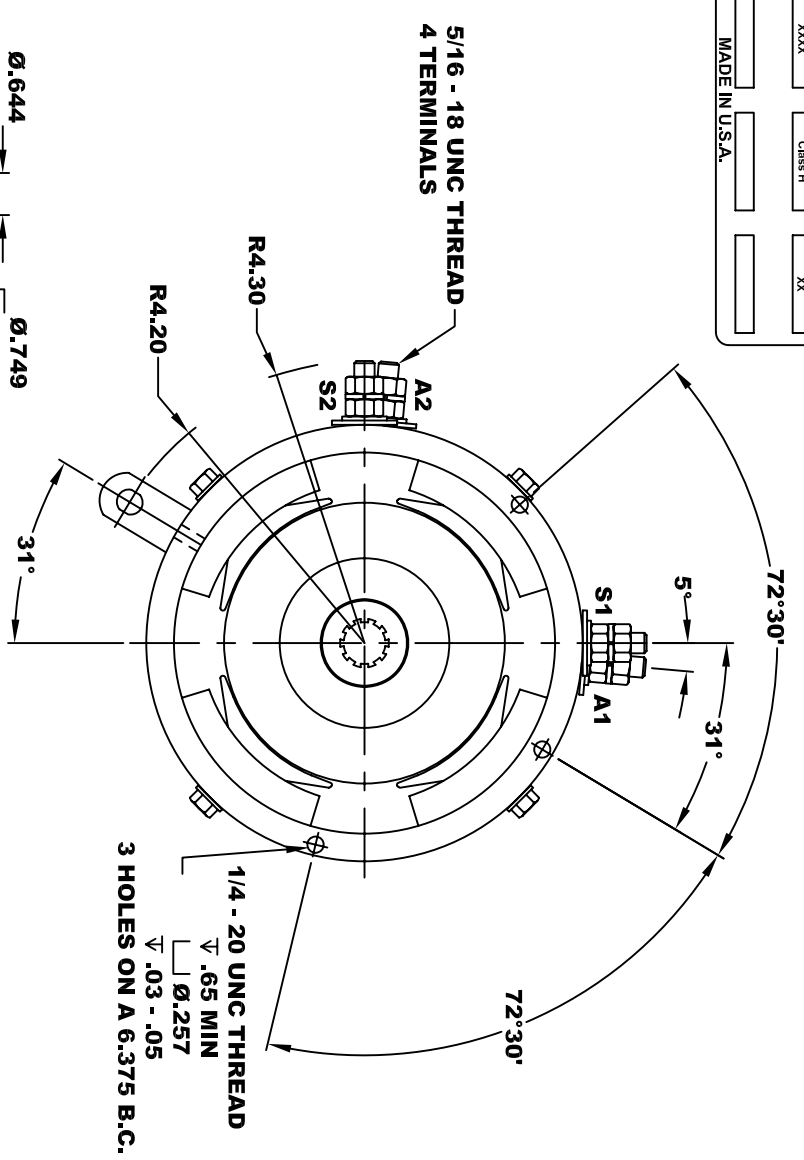
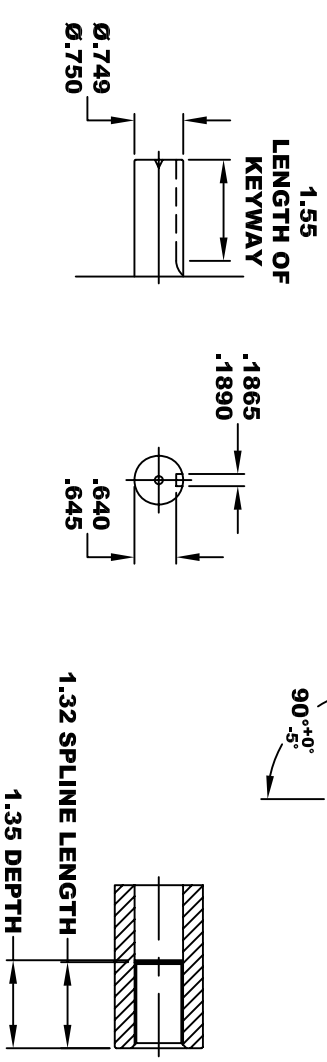
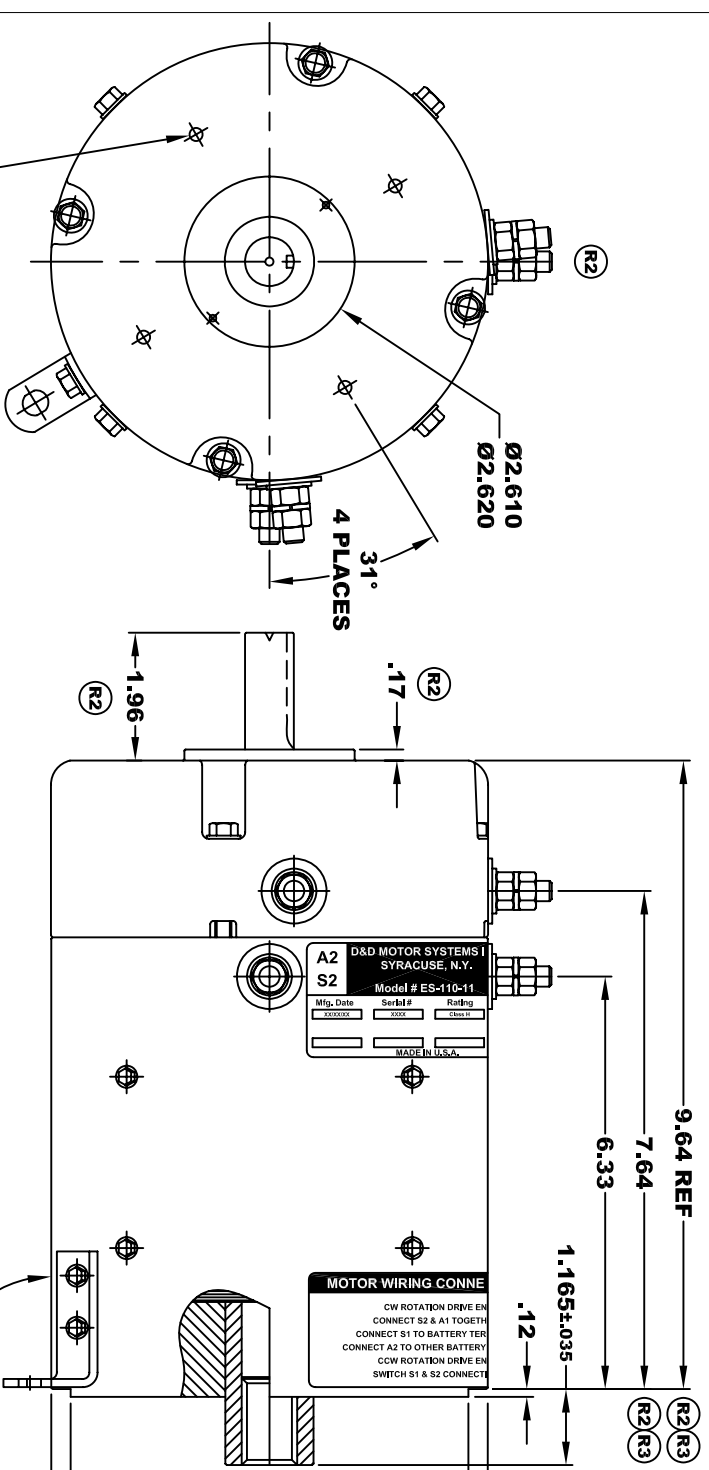

**MOTOR WIRING CONNECTIONS:**  
**CW ROTATION DRIVE END**  
 CONNECT S2 & A1 TOGETHER  
 CONNECT S1 TO BATTERY TERMINAL  
**CCW ROTATION DRIVE END**  
 CONNECT A2 TO OTHER BATTERY TERMINAL  
 SWITCH S1 & S2 CONNECTIONS

**MOTOR WEIGHT 54 LBS**  
**CLASS "H" INSULATION**  
**PERFORMANCE SPEC: 11**

**D & D MOTOR SYSTEMS INC**  
**MOTOR OUTLINE**

THIS PRINT IS THE PROPERTY OF D&D MOTOR SYSTEMS INC.  
 DO NOT SCALE  
 WORK TO DIMENSIONS  
 TOLERANCES UNLESS OTHERWISE SPECIFIED ARE AS FOLLOWS  
 .XX \_\_\_\_\_ .01  
 .XXX \_\_\_\_\_ .005  
 .XX ROUGH CASTING \_\_\_\_\_ .03  
 HOLES \_\_\_\_\_ -.001 / +.006  
 ANGLES \_\_\_\_\_ 0°30"

SIZE	DRAWN DATE	RELEASE DATE	DWG NO. / PART NO.	REV
B	5-11-04		ES-110-11 (R1)	R3
SCALE	STF	DRAWN BY	MJG	REV DATE
				12-6-13