

<b>D&amp;D MOTOR SYSTEMS INC.</b>			
<b>SYRACUSE N.Y.</b>			
<b>A2</b>	<b>Model # ES-112-47</b>		<b>A1</b>
<b>F2</b>	Mfg. Date	Serial #	Rating
	XXXXXX	XXXX	CLASS H
			Voltage
			XX
			MADE IN U.S.A.

**TORQUE SPECIFICATION FOR  
POWER CABLE SECURING TOP NUTS**  
5/16-18 UNC (A1 / A2) - 110 IN / LBS MAX  
1/4-20 UNC (F1 / F2) - 50 IN / LBS MAX

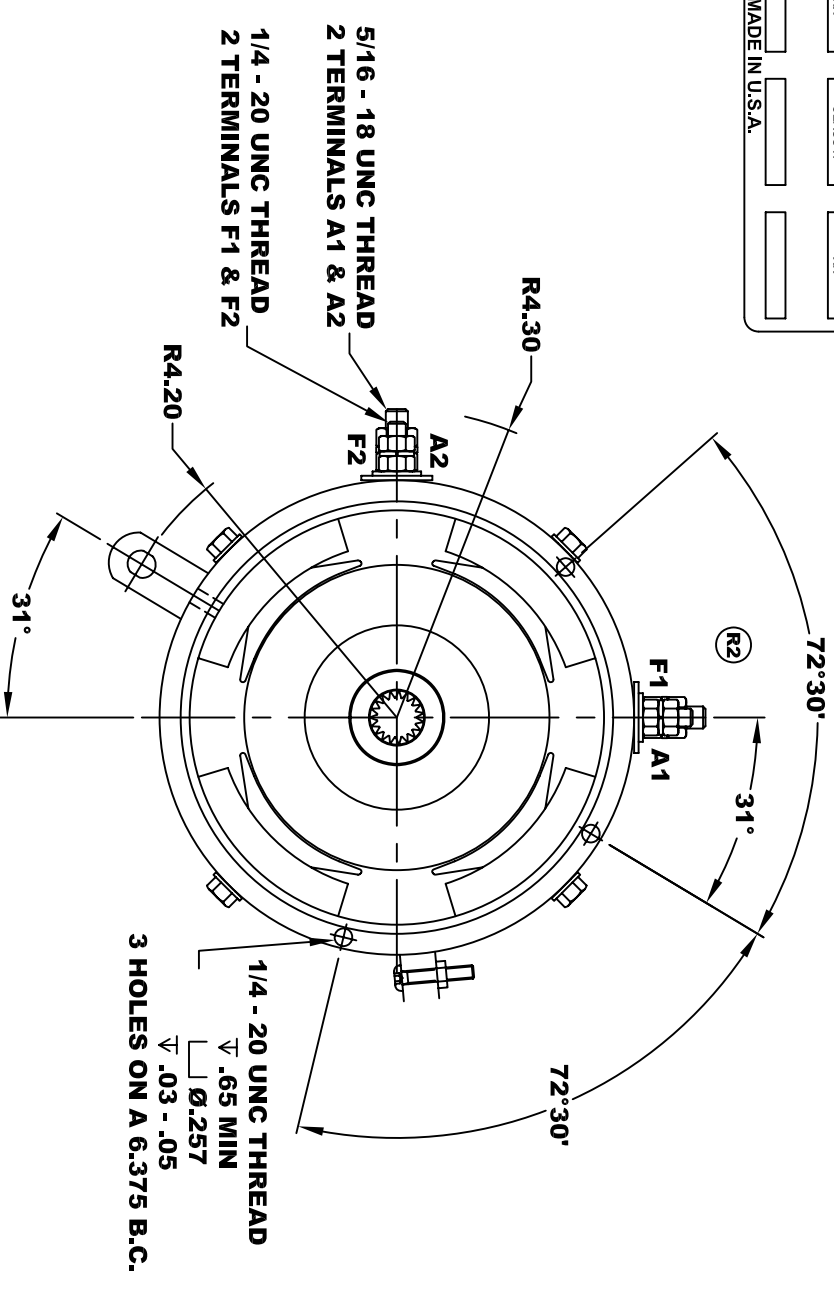
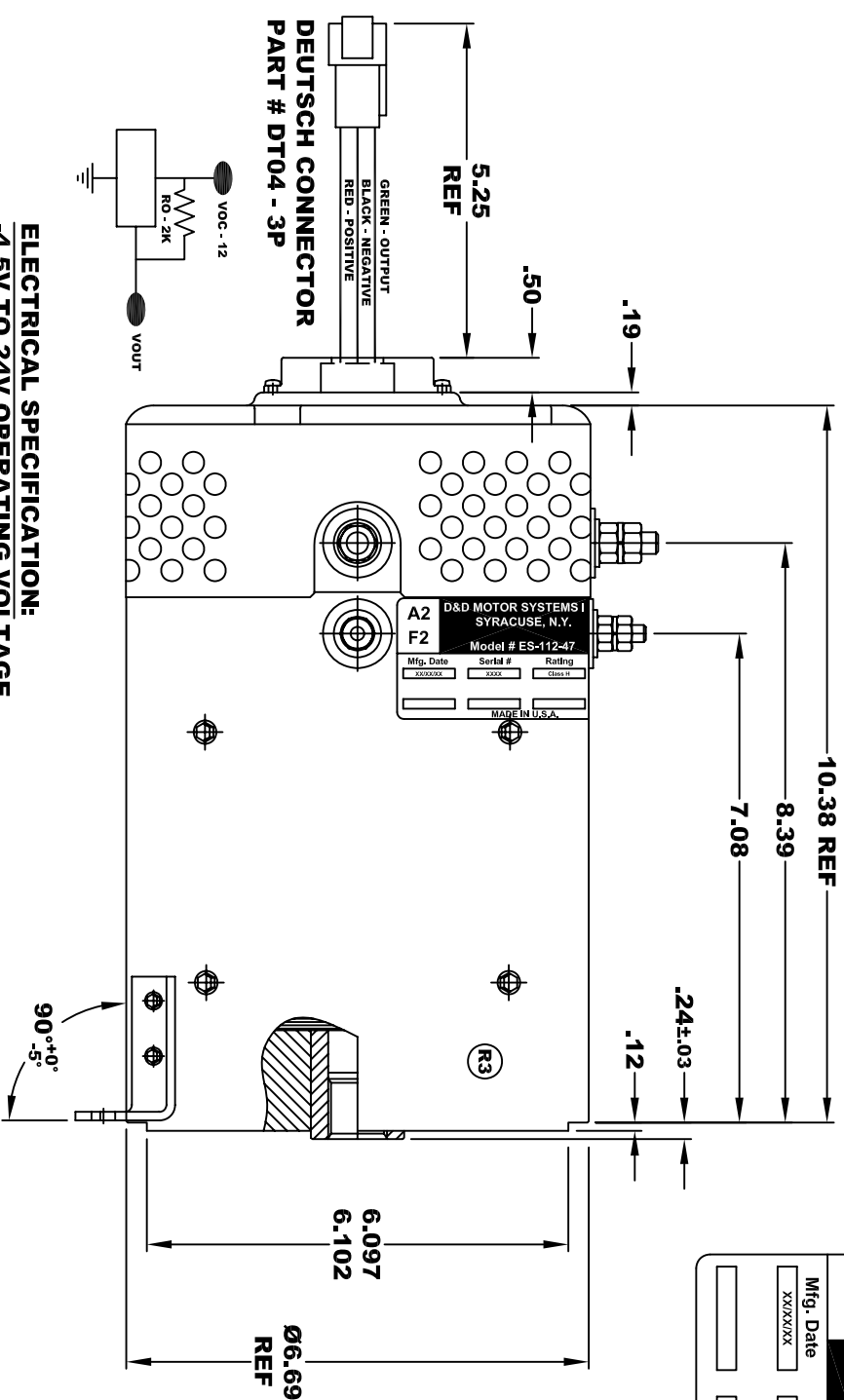

**ELECTRICAL SPECIFICATION:**  
-4.5V TO 24V OPERATING VOLTAGE  
-20°C TO 85°C OPERATING TEMPERATURE  
-CURRENT SINKING UP TO 25mA  
-AN EXTERNAL OUTPUT PULL UP RESISTOR IS REQUIRED  
-SENSOR IS DESIGNED TO OPERATE WITH 4 N/S POLEPAIRS  
-THE OPERATIONAL DISTANCE BETWEEN THE MAGNET  
AND THE HOUSING, INCLUDING ANY RUNOUT  
SHOULD NOT EXCEED .030 INCHES

**INTERNAL INVOLUTE SPLINE SPECIFICATION  
CLASS 5 FILLET ROOT SIDE FIT (PER A.N.S.I. B92.1)**

NO. OF TEETH \_\_\_\_\_ 19  
SPLINE PITCH \_\_\_\_\_ 24 / 48  
PRESSURE ANGLE \_\_\_\_\_ 45°  
BASE Ø \_\_\_\_\_ .5597 REF  
PITCH Ø \_\_\_\_\_ .7916 REF  
MAJOR Ø \_\_\_\_\_ .850 - .859  
FORM Ø \_\_\_\_\_ .835  
MINOR Ø \_\_\_\_\_ .767 - .772  
CIRCULAR SPACE WIDTH \_\_\_\_\_ .0764  
EFFECTIVE SPACE WIDTH \_\_\_\_\_ .0738  
MAX. DIMENSION BETWEEN  
TWO PINS \_\_\_\_\_ .6714  
PIN Ø \_\_\_\_\_ .0800  
SPLINE HARDNESS TO BE R/C 26-34

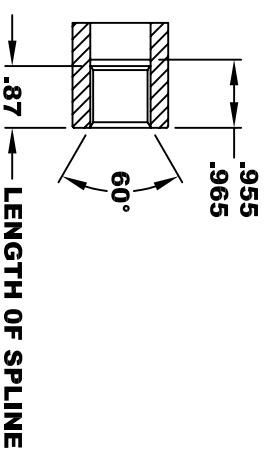

**MOTOR WEIGHT: 57 LBS**  
**CLASS "H" INSULATION**  
**PERFORMANCE SPEC: 47**

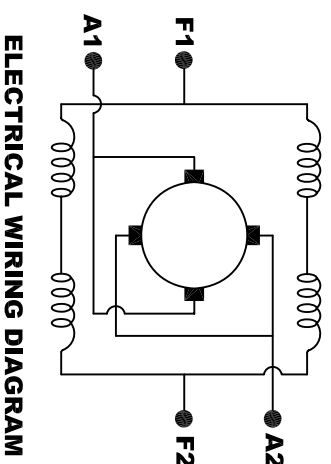

**MOTOR WIRING CONNECTIONS:**  
**CW ROTATION DRIVE END**  
**CONNECT A1 & F1 TO ONE BATTERY TERMINAL**  
**CONNECT A2 & F2 TO OTHER BATTERY TERMINAL**  
**CCW ROTATION DRIVE END**  
**SWITCH F1 & F2 CONNECTIONS**

THIS PRINT IS THE PROPERTY OF D&D MOTOR SYSTEMS INC.  
DO NOT SCALE  
WORK TO DIMENSIONS  
TOLERANCES UNLESS OTHERWISE SPECIFIED ARE AS FOLLOWS  
.XX \_\_\_\_\_ .01  
.XXX \_\_\_\_\_ .005  
.XX ROUGH CASTING \_\_\_\_\_ .03  
HOLES \_\_\_\_\_ -.001 / +.006  
ANGLES \_\_\_\_\_ 0°30"

**D & D MOTOR SYSTEMS INC**  
**MOTOR OUTLINE**

SIZE	DRAWN DATE	RELEASE DATE	DWG NO. / PART NO.	REV
B	4-12-02		ES-112-47 (R2) (R1)	R3
SCALE	STF	DRAWN BY	MJG	REV DATE
				5-28-13