

D&D MOTOR SYSTEMS INC.			
SYRACUSE N.Y.			
A2	F2	A1	F1
Model # ES-112A-50			
Mfg. Date	Serial #	Rating	Voltage
XXXXXX	XXXX	CLASSH	XX
MADE IN U.S.A.			

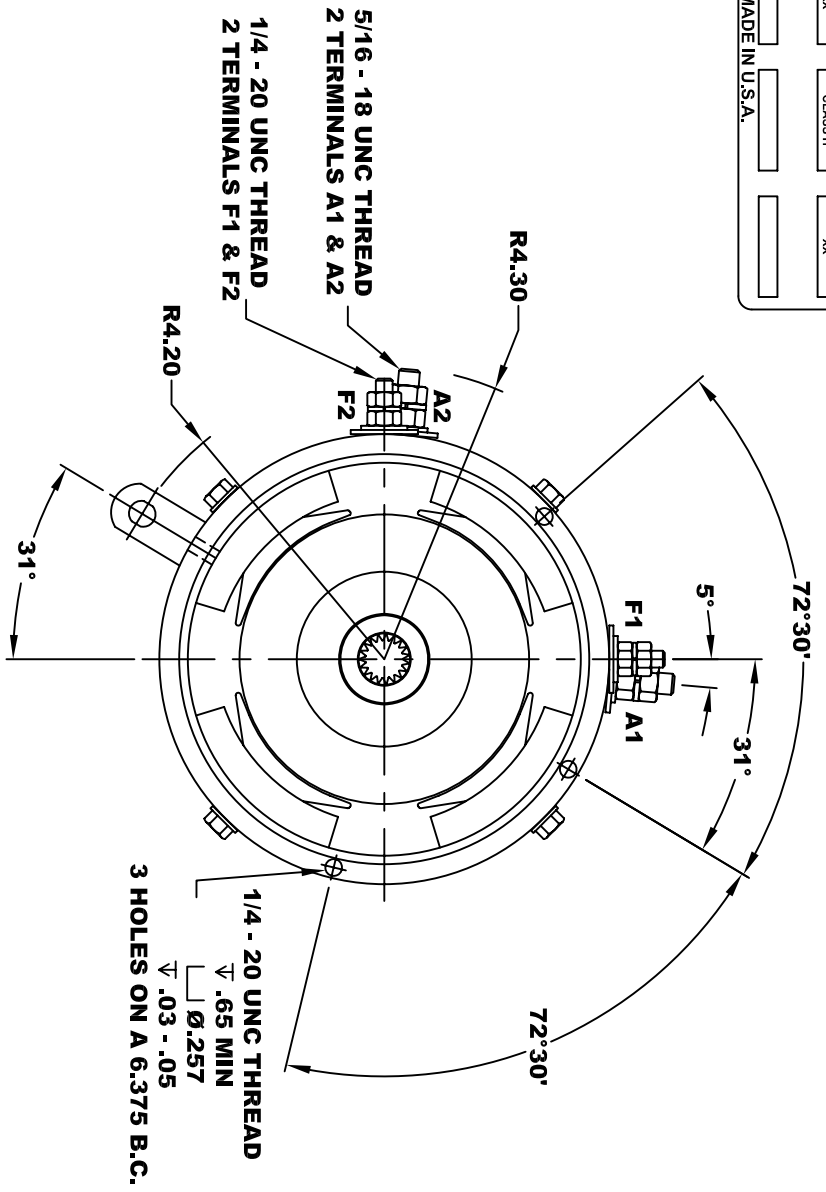

**INTERNAL INVOLUTE SPLINE SPECIFICATION
CLASS 5 FILLET ROOT SIDE FIT (PER A.N.S.I. B92.1)**

- NO. OF TEETH _____ 19
- SPLINE PITCH _____ 24/48
- PRESSURE ANGLE _____ 45°
- BASE Ø _____ .5597 REF
- PITCH Ø _____ .7916 REF
- MAJOR Ø _____ .850 - .859
- FORM Ø _____ .835
- MINOR Ø _____ .767 - .772
- CIRCULAR SPACE WIDTH _____ .0764
- EFFECTIVE SPACE WIDTH _____ .0738
- MAX. DIMENSION BETWEEN TWO PINS _____ .6714
- PIN Ø _____ .0800
- SPLINE HARDNESS TO BE R/C 26-34

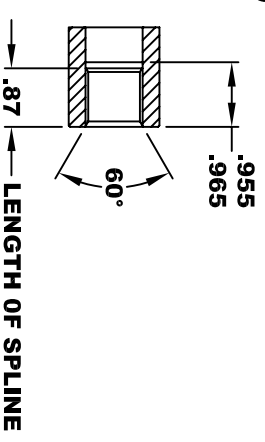

**MOTOR WEIGHT: 57 LBS
CLASS "H" INSULATION
PERFORMANCE SPEC: 50**

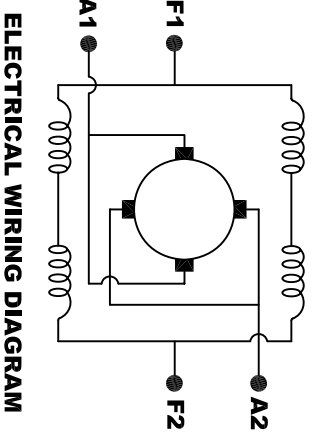

**MOTOR WIRING CONNECTIONS:
CW ROTATION DRIVE END
CONNECT A1 & F1 TO ONE BATTERY TERMINAL
CONNECT A2 & F2 TO OTHER BATTERY TERMINAL
CCW ROTATION DRIVE END
SWITCH F1 & F2 CONNECTIONS**

D & D MOTOR SYSTEMS INC

MOTOR OUTLINE

THIS PRINT IS THE PROPERTY OF D&D MOTOR SYSTEMS INC.
DO NOT SCALE
WORK TO DIMENSIONS
TOLERANCES UNLESS OTHERWISE SPECIFIED ARE AS FOLLOWS

.XXX _____ .005
.XX _____ .01
.XX ROUGH CASTING _____ .03
HOLES _____ -.001 / +.006
ANGLES _____ 0°30"

SIZE	DRAWN DATE	RELEASE DATE	DWG NO. / PART NO.	REV
B	8-24-06		ES-112A-50	R2
SCALE	STF	DRAWN BY	MJG	REV DATE
				5-28-13