

<b>D&amp;D MOTOR SYSTEMS INC.</b>			
<b>A2</b>	<b>SYRACUSE N.Y.</b>		<b>A1</b>
<b>S2</b>	<b>Model # ES-113-26</b>		<b>S1</b>
Mfg. Date	Serial #	Rating	Voltage
XXXXXX	XXXX	CLASS H	XX
MADE IN U.S.A.			

**TORQUE SPECIFICATION FOR  
POWER CABLE SECURING TOP NUTS**  
5/16-18 UNC - 110 IN / LBS MAX

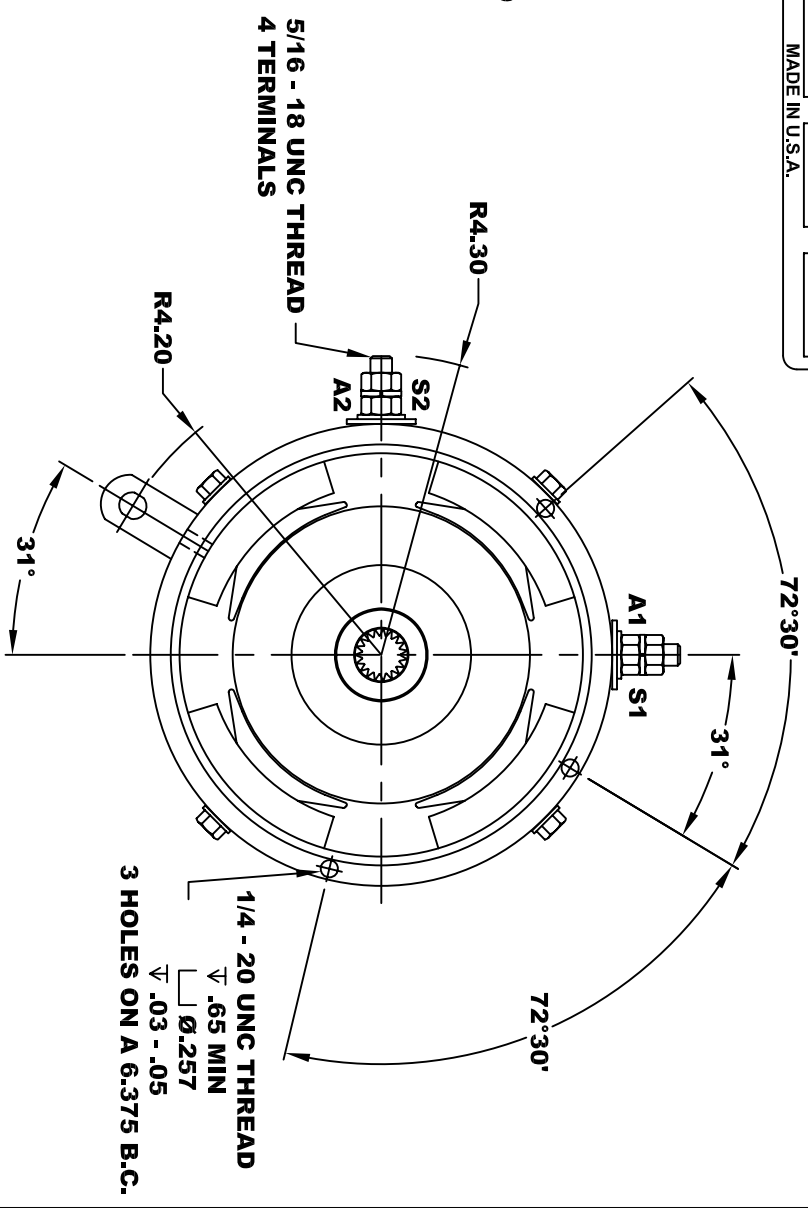
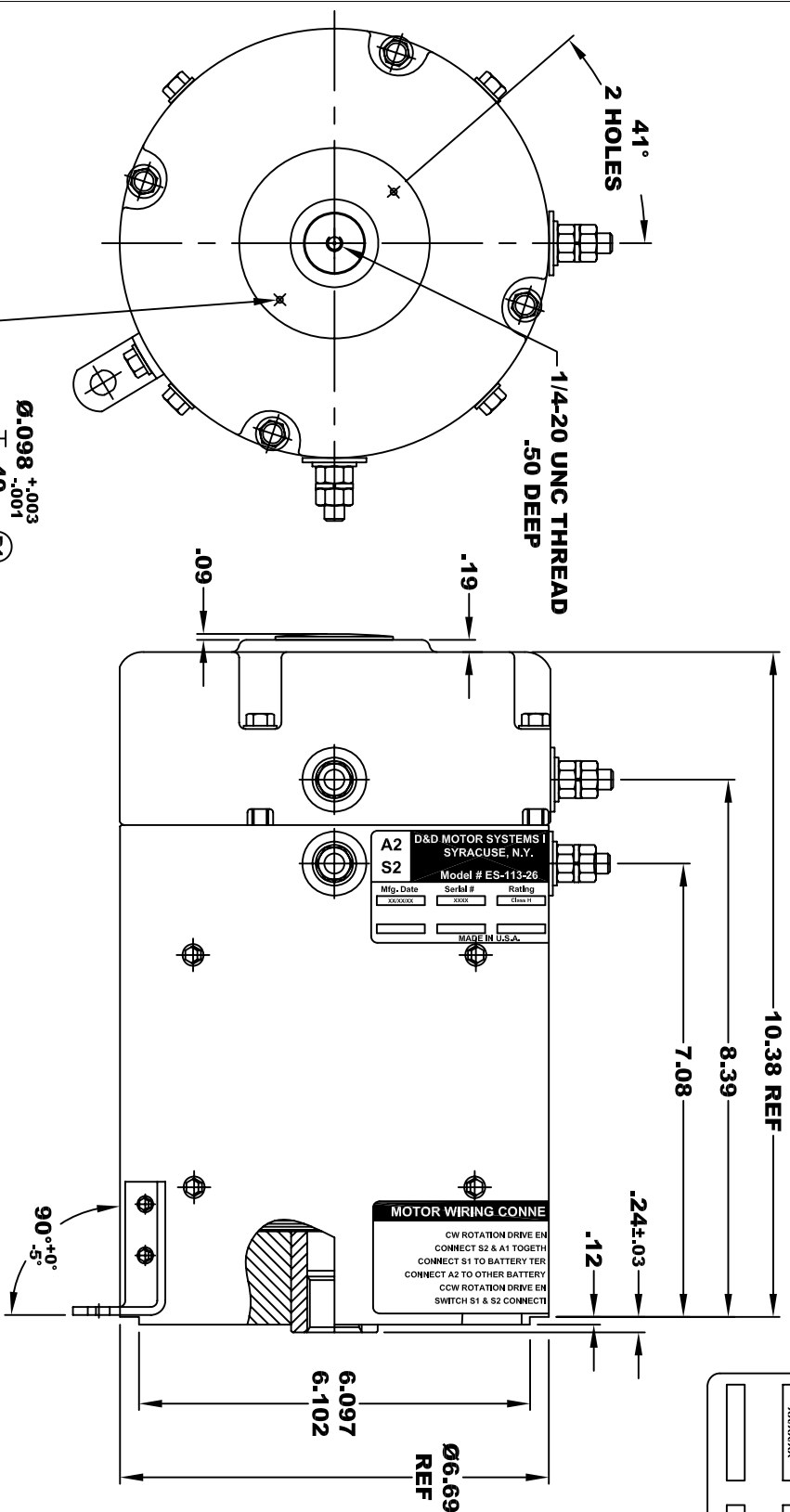

**INTERNAL INVOLUTE SPLINE SPECIFICATION  
CLASS 5 FILET ROOT SIDE FIT (PER A.N.S.I. B92.1)**

NO. OF TEETH	19
SPLINE PITCH	24 / 48
PRESSURE ANGLE	45°
BASE Ø	.5597 REF
PITCH Ø	.7916 REF
MAJOR Ø	.850 - .859
FORM Ø	.835
MINOR Ø	.767 - .772
CIRCULAR SPACE WIDTH	.0764
EFFECTIVE SPACE WIDTH	.0738
MAX. DIMENSION BETWEEN	
TWO PINS	.6714
PIN Ø	.0800
SPLINE HARDNESS TO BE	RC 26-34

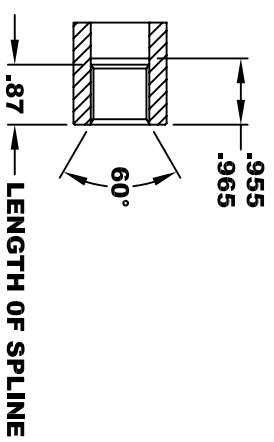

**MOTOR WEIGHT: 57 LBS**  
**CLASS "H" INSULATION**  
**PERFORMANCE SPEC: 26**

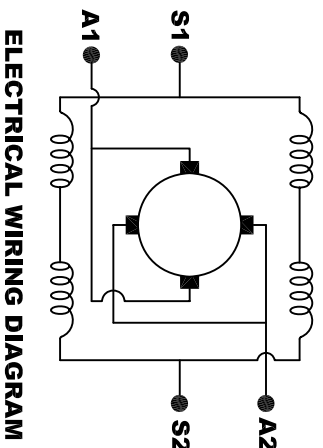

**ELECTRICAL WIRING DIAGRAM**

**MOTOR WIRING CONNECTIONS:**  
**CW ROTATION DRIVE END**  
**CONNECT S2 & A1 TOGETHER**  
**CONNECT S1 TO BATTERY TERMINAL**  
**CW ROTATION DRIVE END**  
**CONNECT A2 TO OTHER BATTERY TERMINAL**  
**SWITCH S1 & S2 CONNECTIONS**

THIS PRINT IS THE PROPERTY OF D&D MOTOR SYSTEMS INC.  
DO NOT SCALE  
WORK TO DIMENSIONS  
TOLERANCES UNLESS OTHERWISE SPECIFIED ARE AS FOLLOWS  
 .XX .005  
 .XXX .01  
 .XX RROUGH CASTING .03  
 HOLES .001 / +.006  
 ANGLES 0°30"

**D & D MOTOR SYSTEMS INC**  
**MOTOR OUTLINE**

SIZE	DRAWN DATE	RELEASE DATE	DWG NO. / PART NO.	REV
B	2-9-05		ES-113-26	R1
SCALE	STF	DRAWN BY	MJG	REV DATE
				9-4-08