

**TORQUE SPECIFICATION FOR
POWER CABLE SECURING TOP NUTS
3/8-16 UNC - 140 IN / LBS MAX**

D&D MOTOR SYSTEMS INC.			
SYRACUSE N.Y.			
A2	Model # ES-114-6		A1
S2	Mfg. Date	Serial #	Rating
	XXXXXX	XXXX	CLASS H
			Voltage
			XX
			MADE IN U.S.A.

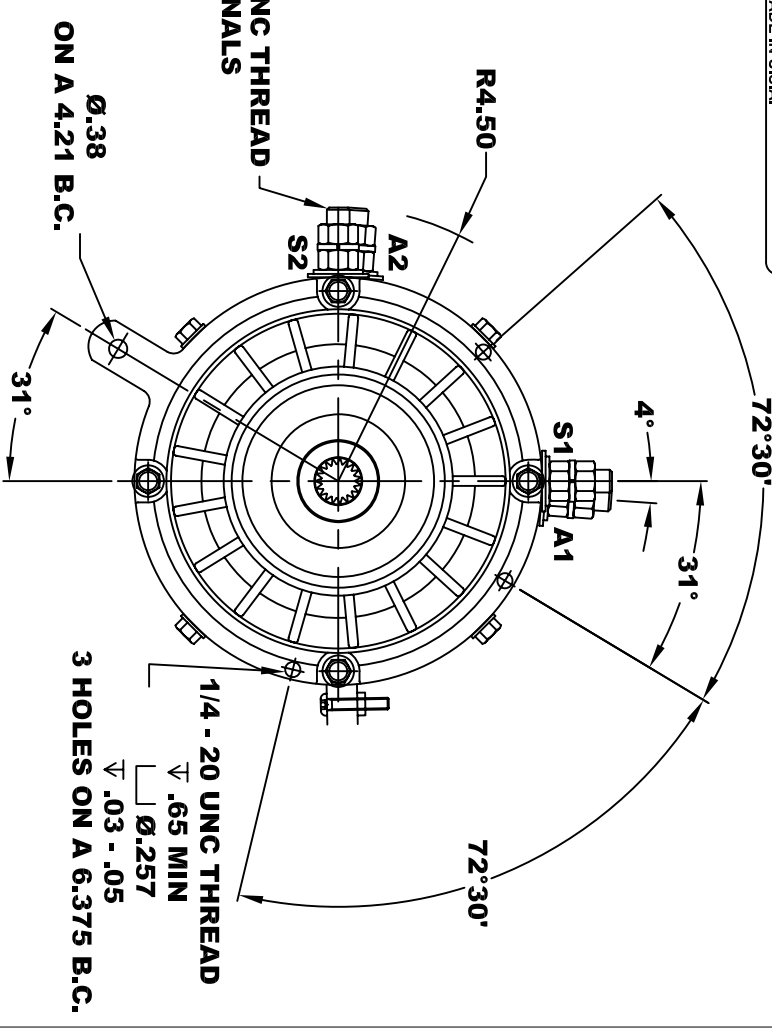
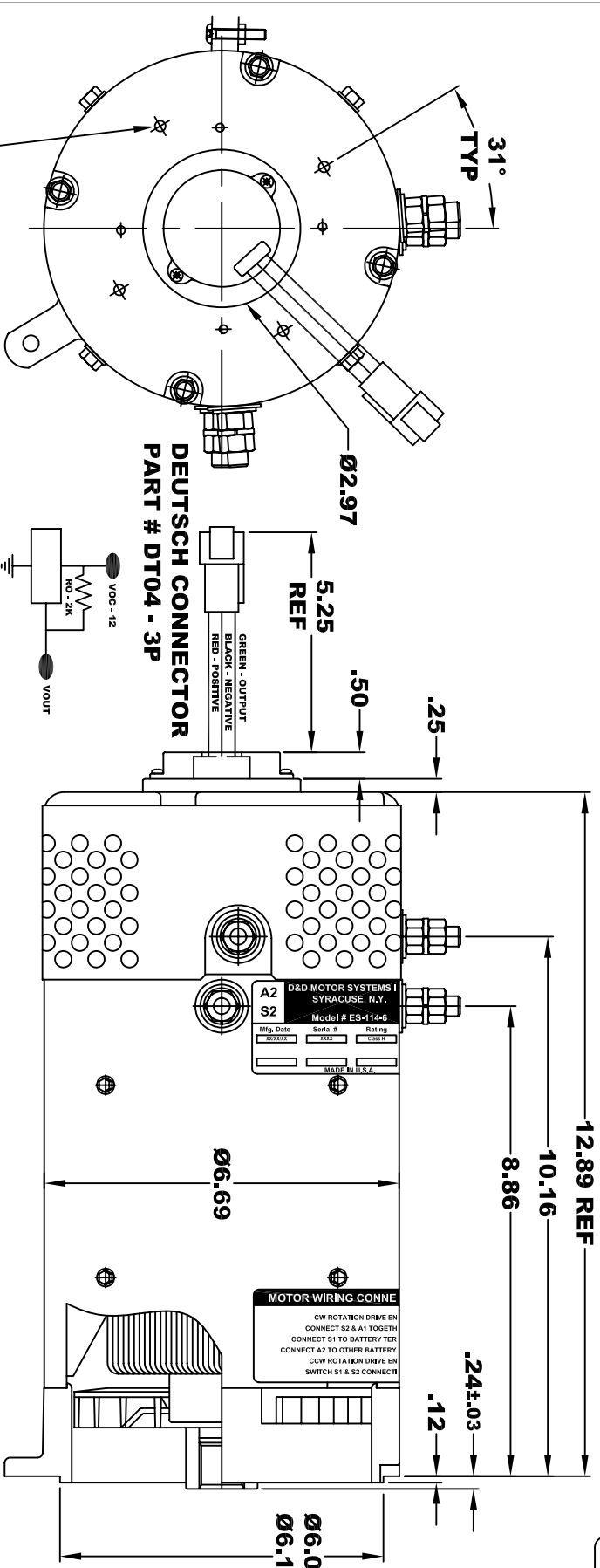

ELECTRICAL SPECIFICATION:
 -4.5V TO 24V OPERATING VOLTAGE
 -20°C TO 85°C OPERATING TEMPERATURE
 -CURRENT SINKING UP TO 25mA
 -AN EXTERNAL OUTPUT PULL UP RESISTOR IS REQUIRED
 -SENSOR IS DESIGNED TO OPERATE WITH 4 N/S POLEPAIRS
 AND THE HOUSING, INCLUDING ANY RUNOUT
 SHOULD NOT EXCEED .030 INCHES

**INTERNAL INVOLUTE SPLINE SPECIFICATION
CLASS 5 FILLET ROOT SIDE FIT (PER A.N.S.I. B92.1)**

NO. OF TEETH	19
SPLINE PITCH	24 / 48
PRESSURE ANGLE	45°
BASE Ø	.5597 REF
PITCH Ø	.7916 REF
MAJOR Ø	.850 - .859
FORM Ø	.835
MINOR Ø	.767 - .772
CIRCULAR SPACE WIDTH	.0764
EFFECTIVE SPACE WIDTH	.0738
MAX. DIMENSION BETWEEN TWO PINS	.6714
PIN Ø	.0800
SPLINE HARDNESS TO BE R/C	26-34

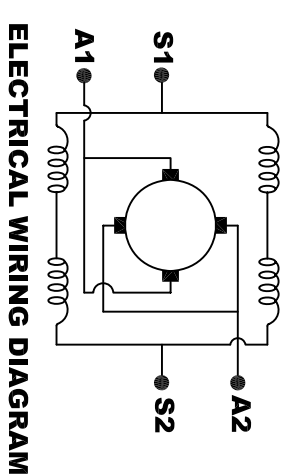
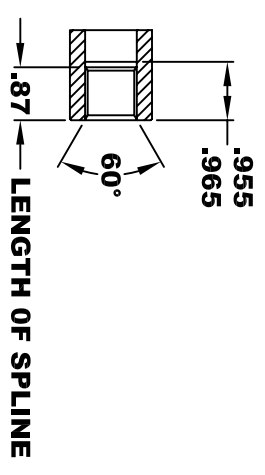

MOTOR WIRING CONNECTIONS:
 CW ROTATION DRIVE END
 CONNECT S2 & A1 TOGETHER
 CONNECT S1 TO BATTERY TERMINAL
 CONNECT A2 TO OTHER BATTERY TERMINAL
 CCW ROTATION DRIVE END
 SWITCH S1 & S2 CONNECTIONS

**MOTOR WEIGHT XX LBS
CLASS "H" INSULATION
PERFORMANCE SPEC: 6**

THIS PRINT IS THE PROPERTY OF D&D MOTOR SYSTEMS INC.
 DO NOT SCALE
 WORK TO DIMENSIONS
 TOLERANCES UNLESS OTHERWISE SPECIFIED ARE AS FOLLOWS
 .XX .01
 .XXX .005
 .XX RROUGH CASTING .03
 HOLES -.001 / +.006
 ANGLES 0°30"

D & D MOTOR SYSTEMS INC			
MOTOR OUTLINE			
SIZE	DRAWN DATE	RELEASE DATE	DWG NO. / PART NO.
B	2-10-05		ES-114-6
SCALE	STF	DRAWN BY	MJG
			REV DATE