

| | | | | | |
|----------------|----------|-----------------------------------|---------|-----------|--|
| A2 | | D&D MOTOR SYSTEMS INC. | | A1 | |
| S2 | | SYRACUSE N.Y. | | S1 | |
| | | Model # ES-15-21 | | | |
| Mfg. Date | Serial # | Rating | Voltage | | |
| XX/XX/XX | XXXX | CLASS H | 36 / 48 | | |
| | | | | | |
| MADE IN U.S.A. | | | | | |

**TORQUE SPECIFICATION FOR
POWER CABLE SECURING TOP NUTS
5/16-18 UNC - 110 IN / LBS MAX**

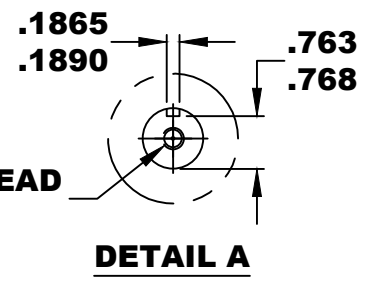

**MOTOR WEIGHT: 63 LBS
CLASS "H" INSULATION
PERFORMANCE SPEC: 21 / K-254**

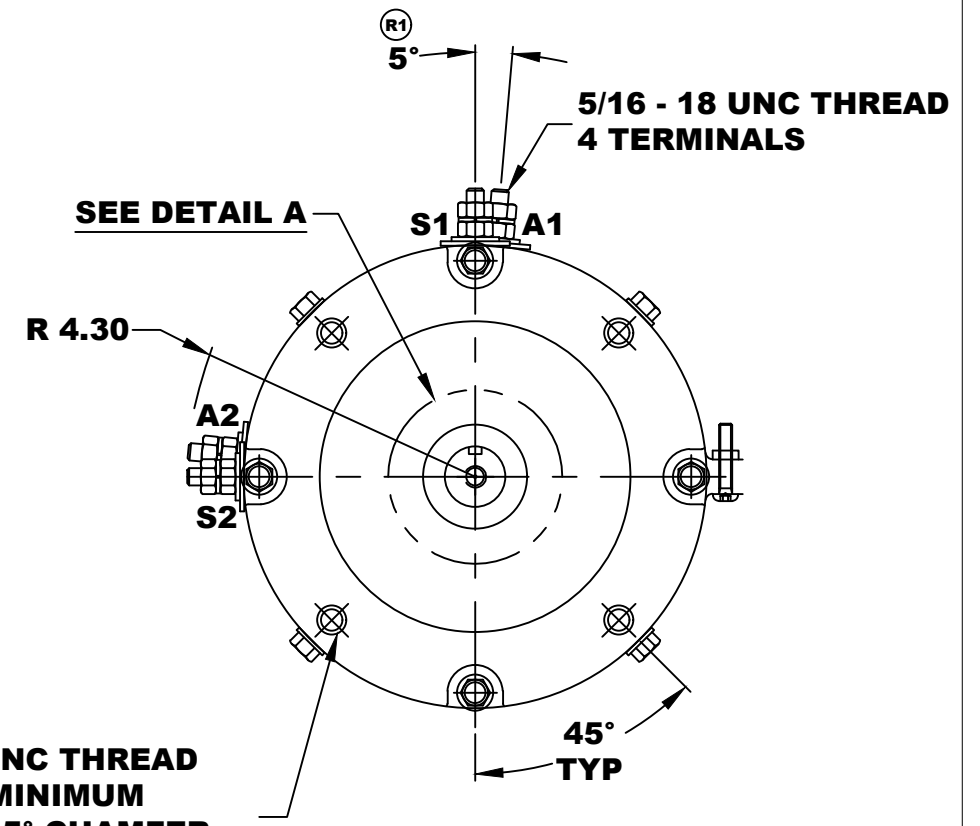
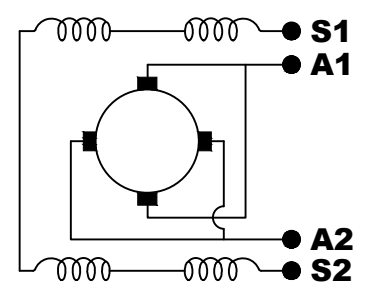

**MOTOR WIRING CONNECTIONS:
CW ROTATION DRIVE END
CONNECT S2 & A1 TOGETHER
CONNECT S1 TO BATTERY TERMINAL
CCW ROTATION DRIVE END
CONNECT A2 TO OTHER BATTERY TERMINAL
SWITCH S1 & S2 CONNECTIONS**

THIS PRINT IS THE PROPERTY OF D&D MOTOR SYSTEMS INC.

DO NOT SCALE
WORK TO DIMENSIONS

TOLERANCES UNLESS OTHERWISE SPECIFIED ARE AS FOLLOWS

| | | |
|-------------------|-------|---------------|
| .XX | _____ | .01 |
| .XXX | _____ | .005 |
| .XX ROUGH CASTING | _____ | .03 |
| HOLES | _____ | -.001 / +.006 |
| ANGLES | _____ | 0'30" |

| | | | | |
|------------------------------------|------------|--------------|--------------------|-----|
| D & D MOTOR SYSTEMS INC | | | | |
| MOTOR OUTLINE | | | | |
| SIZE | DRAWN DATE | RELEASE DATE | DWG NO. / PART NO. | REV |
| B | 3-11-03 | | ES-15-21 (R3) | R3 |
| SCALE | DRAWN BY | REV DATE | | |
| STF | MJG | 5-3-05 | | |