

<b>D&amp;D MOTOR SYSTEMS INC.</b>			
SYRACUSE N.Y.			
<b>A2</b>	<b>A1</b>	<b>F2</b>	<b>F1</b>
Model # ES-162-7			
Mfg. Date	Serial #	Rating	Voltage
XXXX/XX	XXXX	CLASS-H	XX
MADE IN U.S.A.			

**TORQUE SPECIFICATION FOR  
POWER CABLE SECURING TOP NUTS**  
**3/8-16 UNC (A1 / A2) - 140 IN / LBS MAX**  
**1/4-20 UNC (F1 / F2) - 50 IN / LBS MAX**

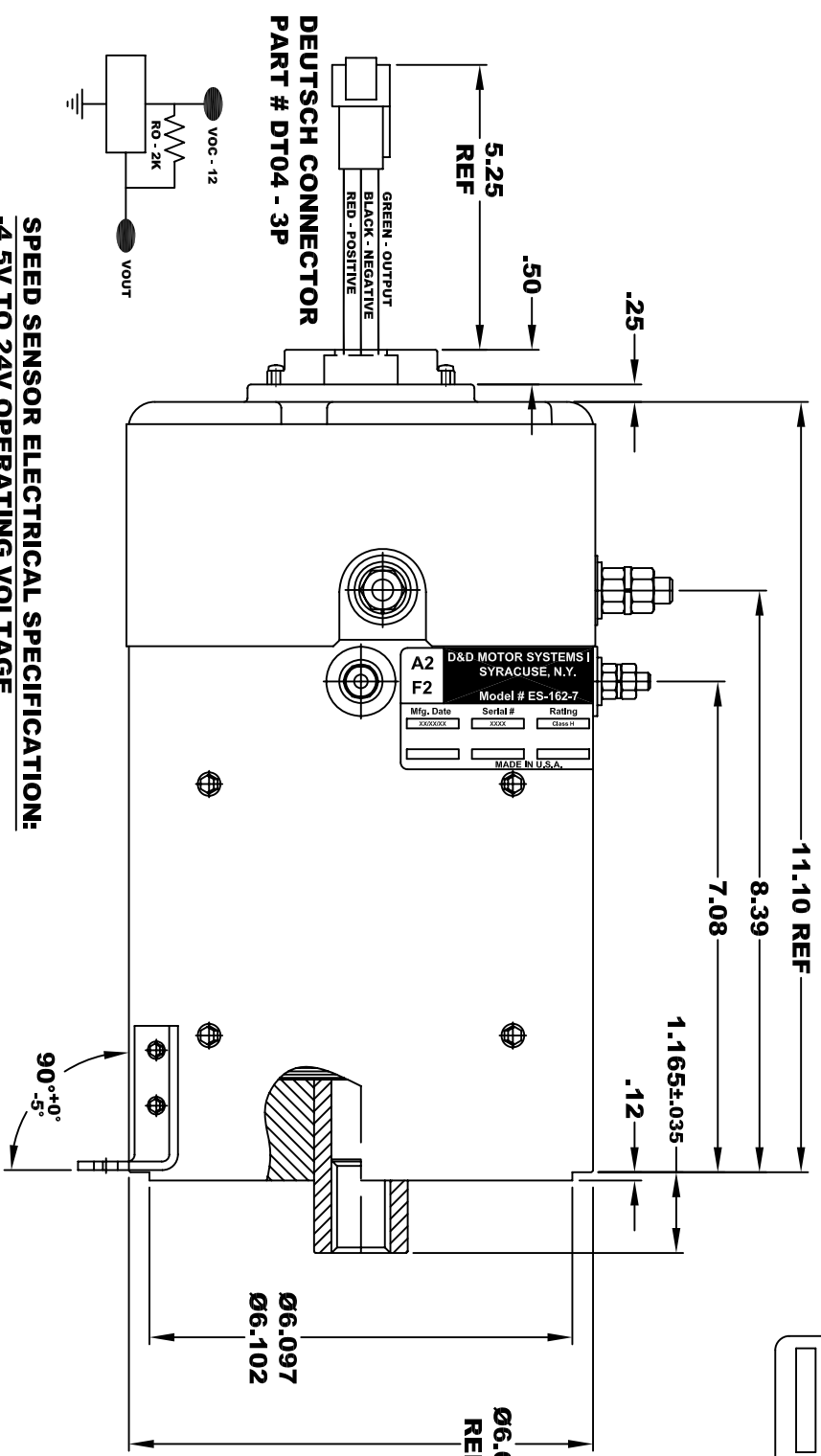

**SPEED SENSOR ELECTRICAL SPECIFICATION:**  
 -4.5V TO 24V OPERATING VOLTAGE  
 -20°C TO 85°C OPERATING TEMPERATURE  
 -CURRENT SINKING UP TO 25mA  
 -AN EXTERNAL PULL UP RESISTOR IS REQUIRED  
 -SENSOR IS DESIGNED TO OPERATE WITH 4 N/S POLEPAIRS  
 -THE OPERATIONAL DISTANCE BETWEEN THE MAGNET  
 AND THE HOUSING, INCLUDING ANY RUNOUT  
 SHOULD NOT EXCEED .030 INCHES

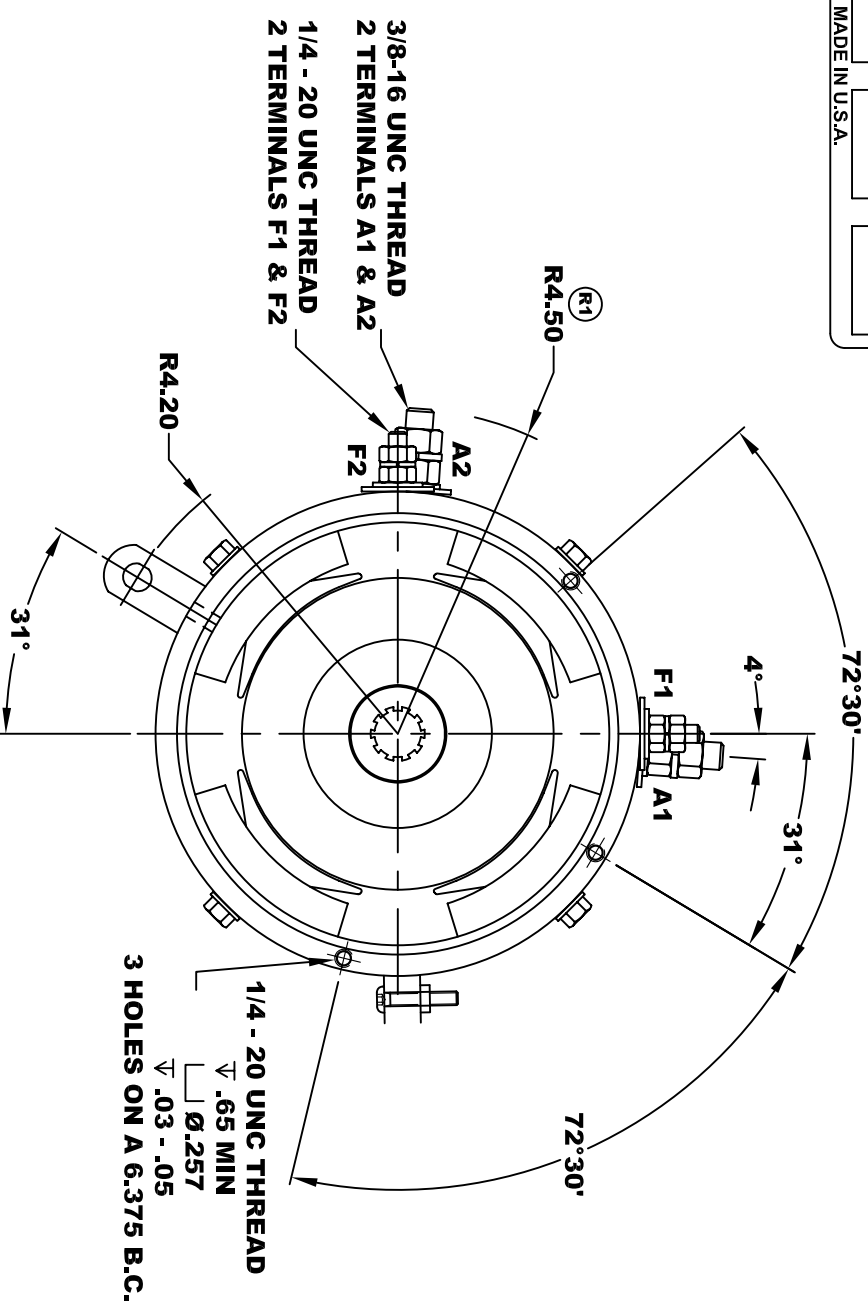
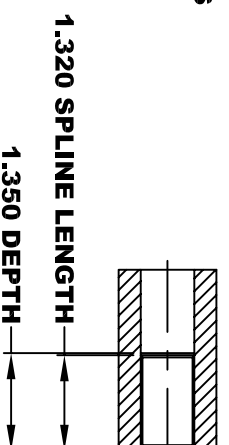

**MOTOR WEIGHT XX LBS**  
**CLASS "H" INSULATION**  
**PERFORMANCE SPEC: 7**

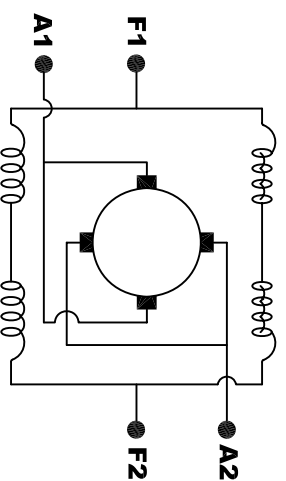

**ELECTRICAL WIRING DIAGRAM**

**MOTOR WIRING CONNECTIONS:**  
**CW ROTATION DRIVE END**  
 CONNECT A1 & F1 TO ONE BATTERY TERMINAL  
 CONNECT A2 & F2 TO OTHER BATTERY TERMINAL  
**CCW ROTATION DRIVE END**  
 SWITCH F1 & F2 CONNECTIONS

THIS PRINT IS THE PROPERTY OF D&D MOTOR SYSTEMS INC.  
 DO NOT SCALE  
 WORK TO DIMENSIONS  
 TOLERANCES UNLESS OTHERWISE SPECIFIED ARE AS FOLLOWS  
 .XX \_\_\_\_\_ .01  
 .XXX \_\_\_\_\_ .005  
 .XX ROUGH CASTING \_\_\_\_\_ .03  
 HOLES \_\_\_\_\_ -.001 / +.006  
 ANGLES \_\_\_\_\_ 0°30"

**D & D MOTOR SYSTEMS INC**  
**MOTOR OUTLINE**

SIZE	DRAWN DATE	RELEASE DATE	DWG NO. / PART NO.	REV
B	6-27-13		ES-162-7	R1
SCALE	STF	DRAWN BY	MJG	REV DATE
				2-24-16