

<b>A2</b>		<b>D&amp;D MOTOR SYSTEMS INC.</b>		<b>A1</b>	
<b>F2</b>		<b>SYRACUSE N.Y.</b>		<b>F1</b>	
Model # ES-19-50					
Mfg. Date	Serial #	Rating	Voltage		
XXXXXX	XXXX	Class H	72		
MADE IN U.S.A.					

**TORQUE SPECIFICATION FOR POWER CABLE SECURING TOP NUTS**  
 5/16-18 UNC (A1 / A2) - 110 IN / LBS MAX  
 1/4-20 UNC (F1 / F2) - 50 IN / LBS MAX

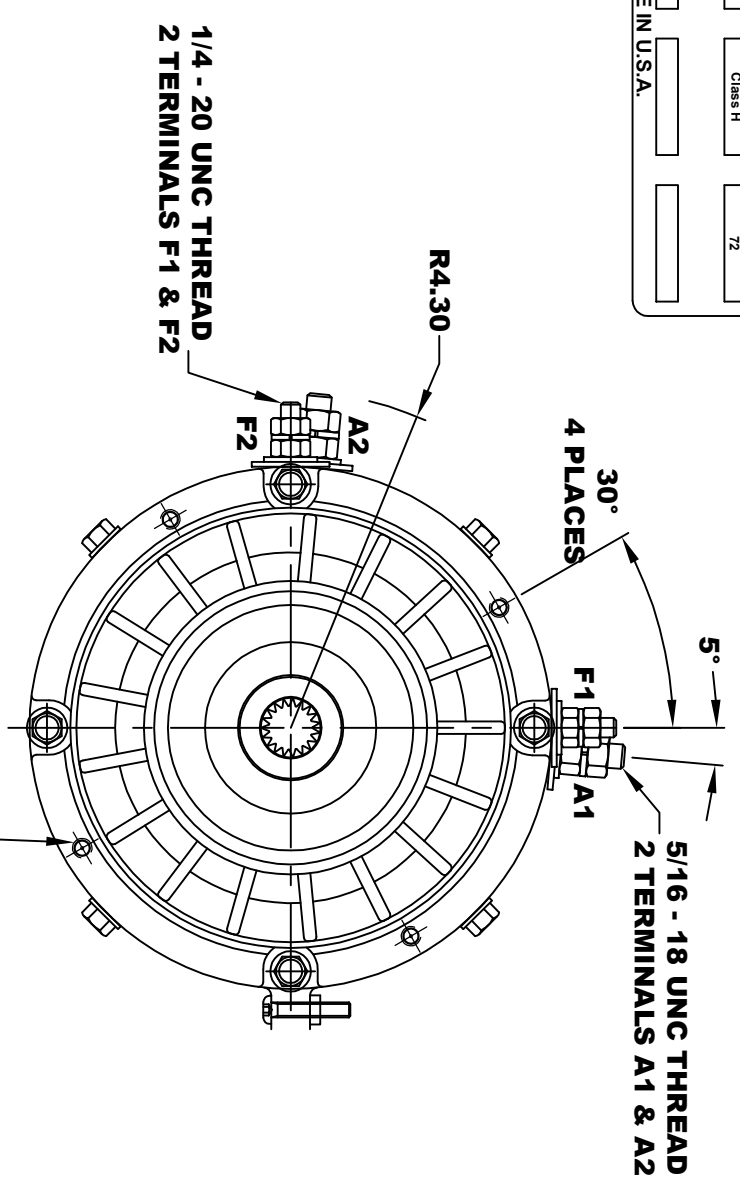

**ELECTRICAL SPECIFICATION:**  
 -4.5V TO 24V OPERATING VOLTAGE  
 -20°C TO 85°C OPERATING TEMPERATURE  
 -CURRENT SINKING UP TO 25mA  
 -AN EXTERNAL OUTPUT PULL UP RESISTOR IS REQUIRED  
 -SENSOR IS DESIGNED TO OPERATE WITH 4 N/S POLEPAIRS  
 -THE OPERATIONAL DISTANCE BETWEEN THE MAGNET AND THE HOUSING, INCLUDING ANY RUNOUT SHOULD NOT EXCEED .030 INCHES

**INTERNAL INVOLUTE SPLINE SPECIFICATION CLASS 5 FILLET ROOT SIDE FIT (PER A.N.S.I. B92.1)**

- NO. OF TEETH \_\_\_\_\_ 19
- SPLINE PITCH \_\_\_\_\_ 24 / 48
- PRESSURE ANGLE \_\_\_\_\_ 45°
- BASE Ø \_\_\_\_\_ .5597 REF
- PITCH Ø \_\_\_\_\_ .7916 REF
- MAJOR Ø \_\_\_\_\_ .850 - .859
- FORM Ø \_\_\_\_\_ .835
- MINOR Ø \_\_\_\_\_ .767 - .772
- CIRCULAR SPACE WIDTH \_\_\_\_\_ .0764
- EFFECTIVE SPACE WIDTH \_\_\_\_\_ .0738
- MAX. DIMENSION BETWEEN TWO PINS \_\_\_\_\_ .6714
- PIN Ø \_\_\_\_\_ .0800
- SPLINE HARDNESS TO BE R/C 26-34

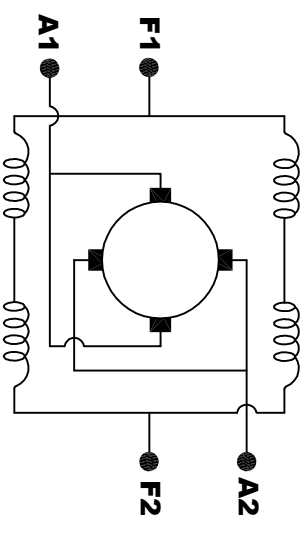
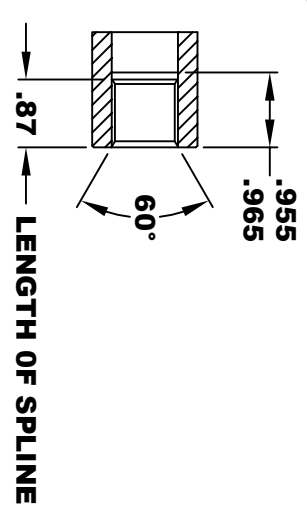

**ELECTRICAL WIRING DIAGRAM**

**MOTOR WIRING CONNECTIONS:**  
**CW ROTATION DRIVE END**  
 CONNECT A1 & F1 TO ONE BATTERY TERMINAL  
 CONNECT A2 & F2 TO OTHER BATTERY TERMINAL  
**CCW ROTATION DRIVE END**  
 SWITCH F1 & F2 CONNECTIONS

THIS PRINT IS THE PROPERTY OF D&D MOTOR SYSTEMS INC.  
 DO NOT SCALE  
 WORK TO DIMENSIONS  
 TOLERANCES UNLESS OTHERWISE SPECIFIED ARE AS FOLLOWS

XXX	.005
.XX	.01
.XX	.03
.XX	.001 / +.006
ANGLES	0.30"

**D & D MOTOR SYSTEMS INC**  
**MOTOR OUTLINE**

SIZE	DRAWN DATE	RELEASE DATE	DWG NO. / PART NO.	REV
B	3-8-19		ES-19-50	
SCALE	STF	DRAWN BY	MJG	REV DATE