

<b>A2</b>		<b>D&amp;D MOTOR SYSTEMS INC.</b>		<b>A1</b>	
<b>F2</b>		<b>SYRACUSE N.Y.</b>		<b>F1</b>	
<b>Model # ES-24A</b>					
Mfg. Date	Serial #	Rating	Duty		
XX/XX/XX	XXXX	CLASS 41	S2-60 MIN		
Voltage	Current	R.P.M.	H.P.		
70.1	75/70	3875	6.0		
MADE IN U.S.A.					

**TORQUE SPECIFICATION FOR  
POWER CABLE SECURING TOP NUTS**  
5/16-18 UNC (A1 / A2) - 110 IN / LBS MAX  
1/4-20 UNC (F1 / F2) - 50 IN / LBS MAX

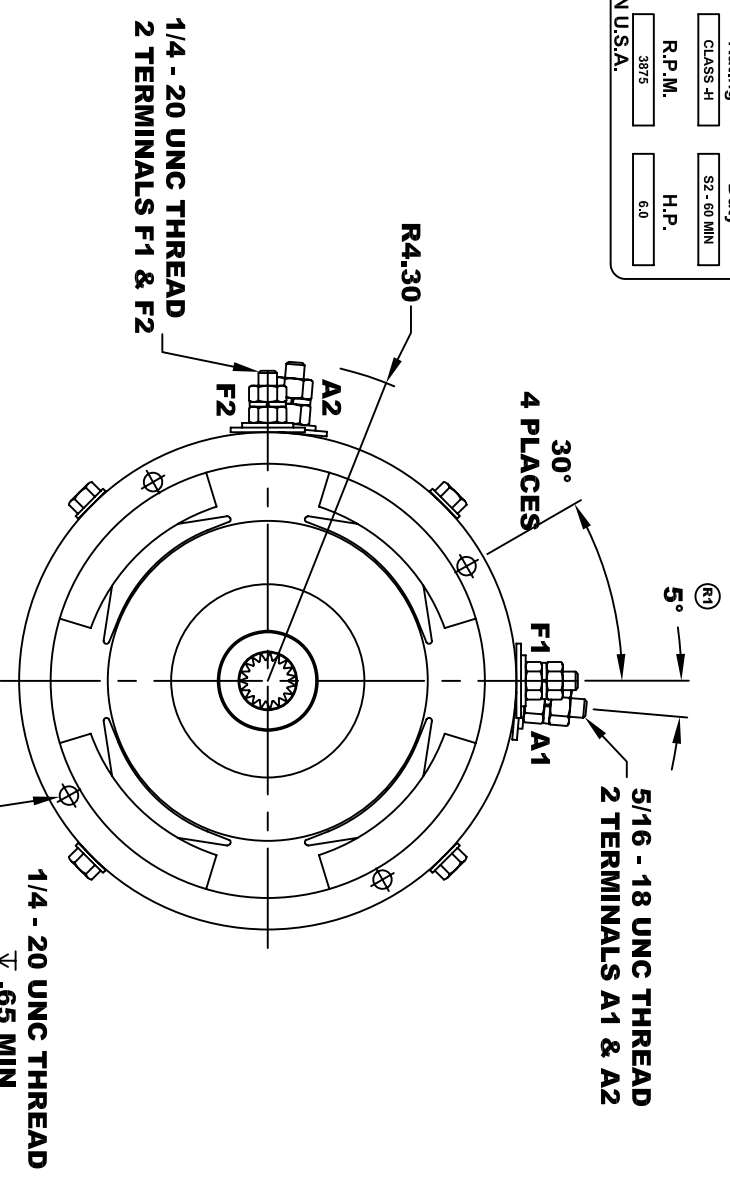
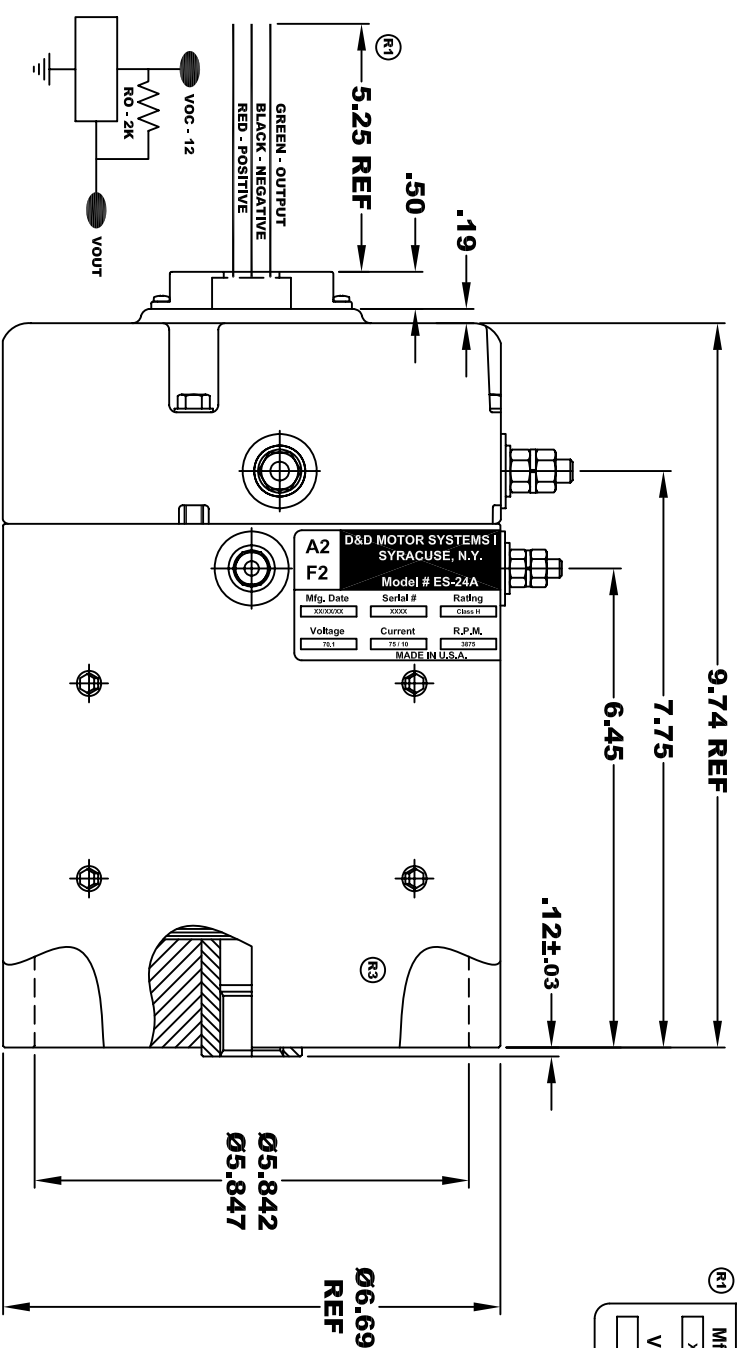

**SPEED SENSOR ELECTRICAL SPECIFICATION:**  
-4.5V TO 24V OPERATING VOLTAGE  
-20°C TO 85°C OPERATING TEMPERATURE  
-CURRENT SINKING UP TO 25mA  
-AN EXTERNAL OUTPUT PULL UP RESISTOR IS REQUIRED  
-SENSOR IS DESIGNED TO OPERATE WITH 4 N/S POLEPAIRS  
-THE OPERATIONAL DISTANCE BETWEEN THE MAGNET  
AND THE HOUSING, INCLUDING ANY RUNOUT  
SHOULD NOT EXCEED .030 INCHES

**INTERNAL INVOLUTE SPLINE SPECIFICATION  
CLASS 5 FILLET ROOT SIDE FIT (PER A.N.S.I. B92.1)**

NO. OF TEETH	19
SPLINE PITCH	24 / 48
PRESSURE ANGLE	45°
BASE Ø	.5597 REF
PITCH Ø	.7916 REF
MAJOR Ø	.850 - .859
FORM Ø	.835
MINOR Ø	.767 - .772
CIRCULAR SPACE WIDTH	.0764
EFFECTIVE SPACE WIDTH	.0738
MAX. DIMENSION BETWEEN TWO PINS	.6714
PIN Ø	.0800
SPLINE HARDNESS TO BE R/C 26-34	

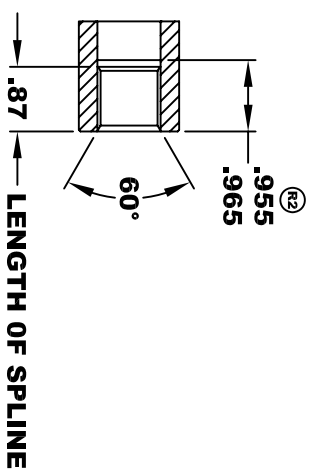

**MOTOR WEIGHT: 53 LBS**  
**CLASS "H" INSULATION**  
**PERFORMANCE SPEC: 10**

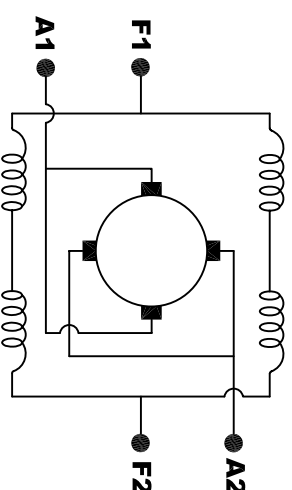

**ELECTRICAL WIRING DIAGRAM**

**MOTOR WIRING CONNECTIONS:**  
**CW ROTATION DRIVE END**  
**CONNECT A1 & F1 TO ONE BATTERY TERMINAL**  
**CONNECT A2 & F2 TO OTHER BATTERY TERMINAL**  
**CCW ROTATION DRIVE END**  
**SWITCH F1 & F2 CONNECTIONS**

**D & D MOTOR SYSTEMS INC**

**MOTOR OUTLINE**

THIS PRINT IS THE PROPERTY OF D&D MOTOR SYSTEMS INC.  
DO NOT SCALE  
WORK TO DIMENSIONS  
TOLERANCES UNLESS OTHERWISE SPECIFIED ARE AS FOLLOWS  
.XX \_\_\_\_\_ .01  
.XXX \_\_\_\_\_ .005  
.XX ROUGH CASTING \_\_\_\_\_ .03  
HOLES \_\_\_\_\_ -.001 / +.006  
ANGLES \_\_\_\_\_ 0°30"

SIZE	DRAWN DATE	RELEASE DATE	DWG NO. / PART NO.	REV
B	12-12-02		ES-24A	R3
SCALE	STF	DRAWN BY	MJG	REV DATE
				2-13-13