

**SPEED SENSOR ELECTRICAL SPECIFICATION:**  
 -4.5V TO 24V OPERATING VOLTAGE  
 -20°C TO 85°C OPERATING TEMPERATURE  
 -CURRENT SINKING UP TO 25mA  
 -AN EXTERNAL OUTPUT PULL UP RESISTOR IS REQUIRED  
 -SENSOR IS DESIGNED TO OPERATE WITH 4 N/S POLEPAIRS  
 THE OPERATIONAL DISTANCE BETWEEN THE MAGNET  
 AND THE HOUSING, INCLUDING ANY RUNOUT  
 SHOULD NOT EXCEED .030 INCHES

**INTERNAL INVOLUTE SPLINE SPECIFICATION  
 CLASS 5 FILLET ROOT SIDE FIT (PER A.N.S.I. B92.1)**

NO. OF TEETH \_\_\_\_\_ 19  
 SPLINE PITCH \_\_\_\_\_ 24 / 48  
 PRESSURE ANGLE \_\_\_\_\_ 45°  
 BASE Ø \_\_\_\_\_ .5597 REF  
 PITCH Ø \_\_\_\_\_ .7916 REF  
 MAJOR Ø \_\_\_\_\_ .850 - .859  
 FORM Ø \_\_\_\_\_ .835  
 MINOR Ø \_\_\_\_\_ .767 - .772  
 CIRCULAR SPACE WIDTH \_\_\_\_\_ .0764  
 EFFECTIVE SPACE WIDTH \_\_\_\_\_ .0738  
 MAX. DIMENSION BETWEEN  
 TWO PINS \_\_\_\_\_ .6714  
 PIN Ø \_\_\_\_\_ .0800  
 SPLINE HARDNESS TO BE R/C 26-34

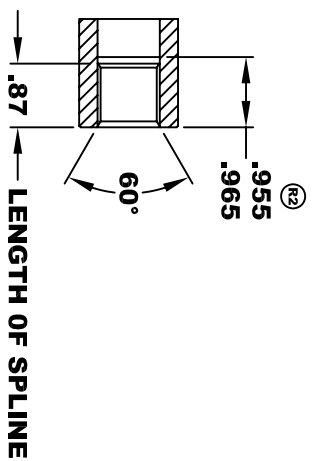

**MOTOR WEIGHT: 53 LBS  
 CLASS "H" INSULATION  
 PERFORMANCE SPEC: 10**

<b>A2</b>		<b>A1</b>	
<b>D&amp;D MOTOR SYSTEMS INC. SYRACUSE N.Y.</b>			
<b>Model # ES-24D</b>			
Mfg. Date	Serial #	Rating	Duty
XXXX/XX	XXXX	CLASS -H	S2 - 60 MIN
Voltage	Current	R.P.M.	H.P.
70.1	75 / 10	3875	6.0
MADE IN U.S.A.			

**TORQUE SPECIFICATION FOR  
 POWER CABLE SECURING TOP NUTS**  
 5/16-18 UNC (A1 / A2) - 110 IN / LBS MAX  
 1/4-20 UNC (F1 / F2) - 50 IN / LBS MAX

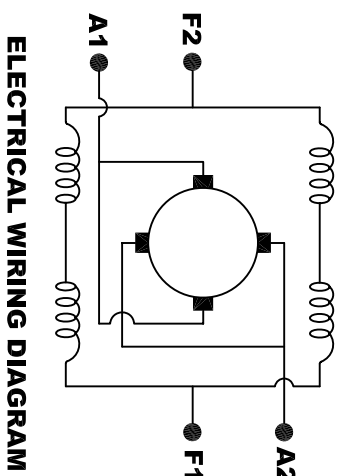
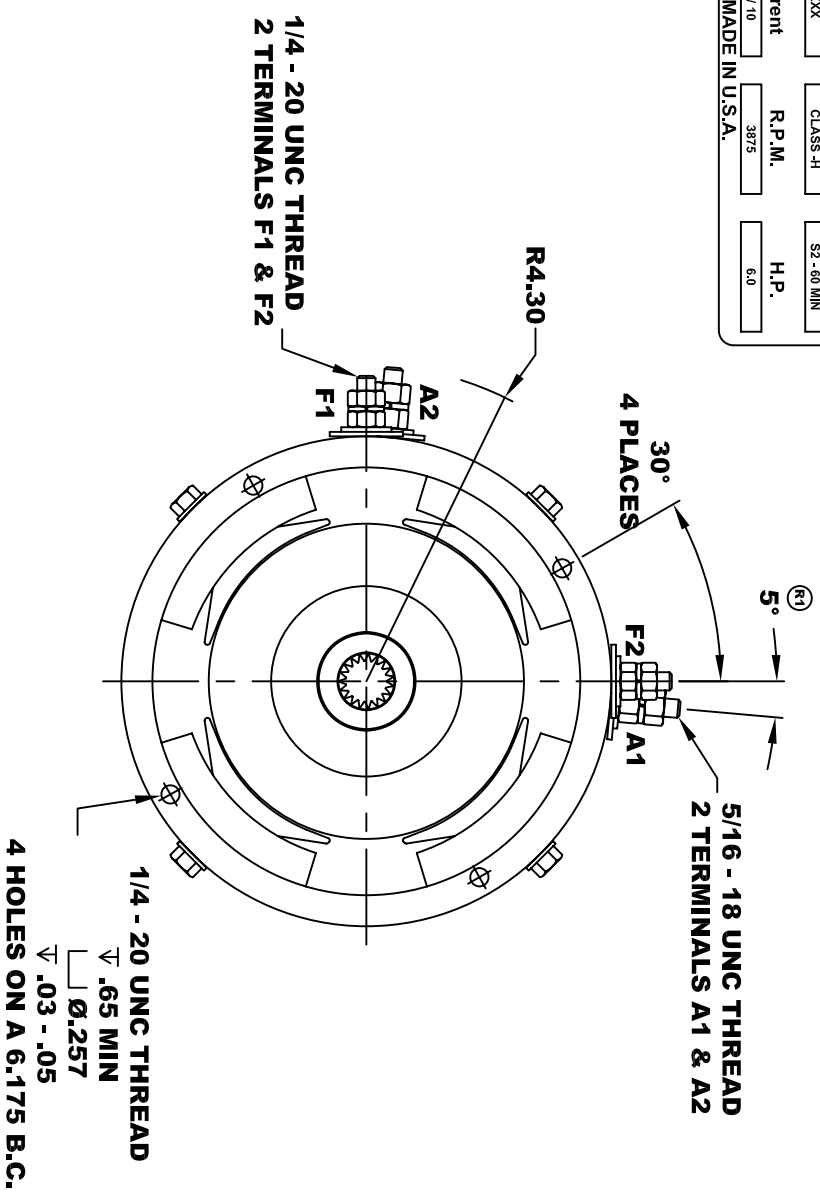

**ELECTRICAL WIRING DIAGRAM**

**MOTOR WIRING CONNECTIONS:**  
 CW ROTATION DRIVE END  
 CONNECT A1 & F2 TO ONE BATTERY TERMINAL  
 CONNECT A2 & F1 TO OTHER BATTERY TERMINAL  
 CCW ROTATION DRIVE END  
 SWITCH F1 & F2 CONNECTIONS

**D & D MOTOR SYSTEMS INC**

**MOTOR OUTLINE**

THIS PRINT IS THE PROPERTY OF D&D MOTOR SYSTEMS INC.  
 DO NOT SCALE  
 WORK TO DIMENSIONS  
 TOLERANCES UNLESS OTHERWISE SPECIFIED ARE AS FOLLOWS

.XXX \_\_\_\_\_ .005  
 .XX \_\_\_\_\_ .01  
 .XX ROUGH CASTING \_\_\_\_\_ .03  
 HOLES \_\_\_\_\_ -.001 / +.006  
 ANGLES \_\_\_\_\_ 0°30"

SIZE	DRAWN DATE	RELEASE DATE	DWG NO. / PART NO.	REV
B	6-5-03		ES-24D	R3
SCALE	STF	DRAWN BY	MJG	REV DATE
				2-13-13