

D&D MOTOR SYSTEMS INC.			
SYRACUSE N.Y.			
A2	Model # ES-24F-14		A1
F2	Mfg. Date	Serial #	Rating
	XXXXXX	XXXX	CLASS-H
			Voltage
			XX
			MADE IN U.S.A.

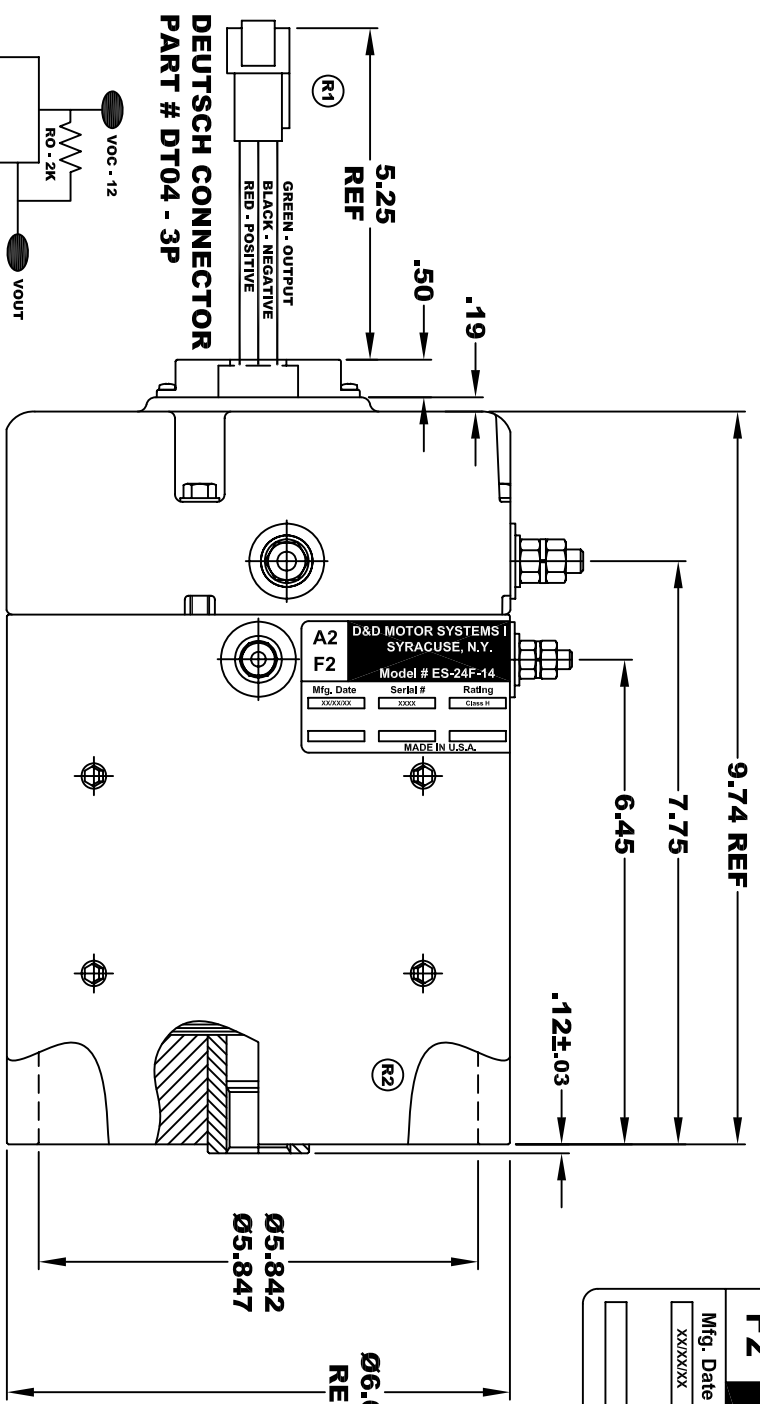

**TORQUE SPECIFICATION FOR
POWER CABLE SECURING TOP NUTS**
5/16-18 UNC (A1 / A2) - 110 IN / LBS MAX
1/4-20 UNC (F1 / F2) - 50 IN / LBS MAX

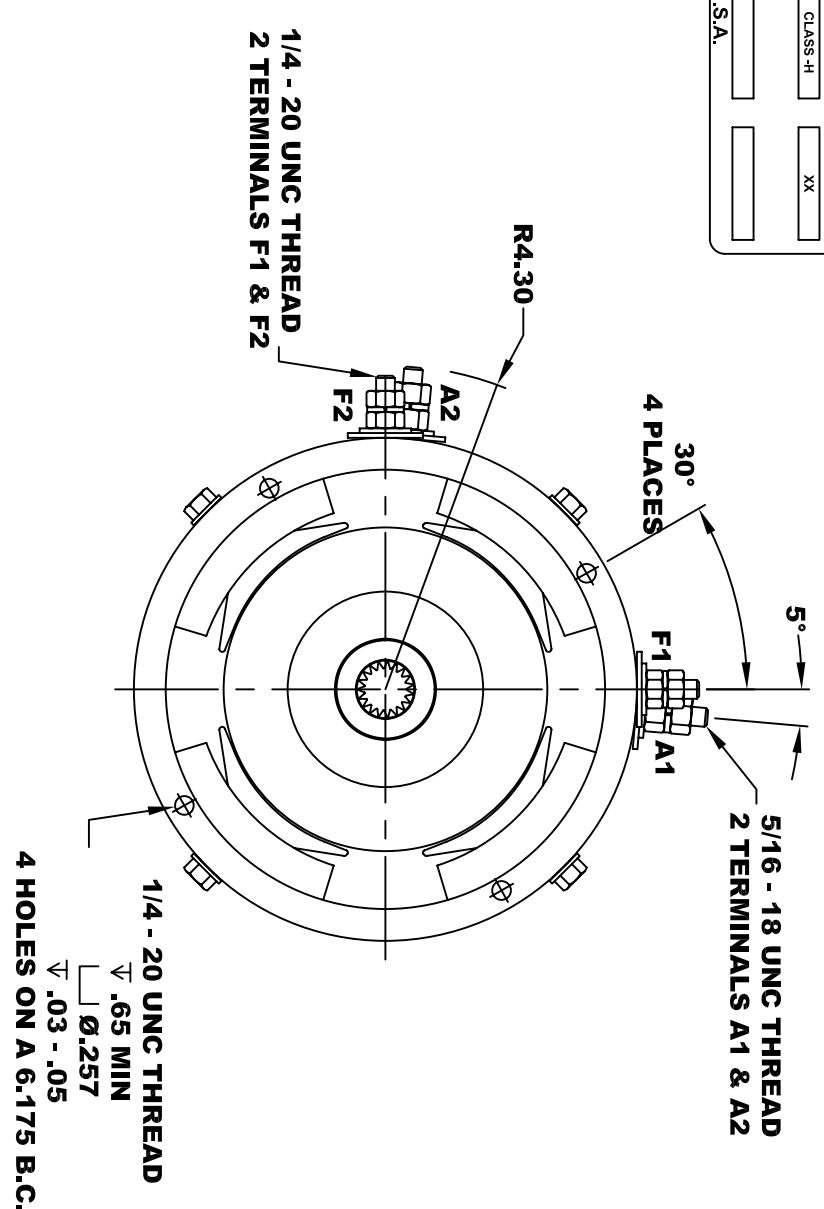

SPEED SENSOR ELECTRICAL SPECIFICATION:
-4.5V TO 24V OPERATING VOLTAGE
-20°C TO 85°C OPERATING TEMPERATURE
-CURRENT SINKING UP TO 25ma
-AN EXTERNAL OUTPUT PULL UP RESISTOR IS REQUIRED
-SENSOR IS DESIGNED TO OPERATE WITH 2 N/S POLEPAIRS
-THE OPERATIONAL DISTANCE BETWEEN THE MAGNET AND THE HOUSING, INCLUDING ANY RUNOUT SHOULD NOT EXCEED .030 INCHES

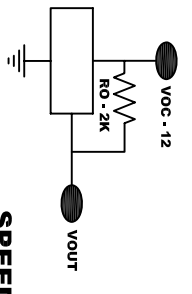

**INTERNAL INVOLUTE SPLINE SPECIFICATION
CLASS 5 FILLET ROOT SIDE FIT (PER A.N.S.I. B92.1)**

NO. OF TEETH	19
SPLINE PITCH	24 / 48
PRESSURE ANGLE	45°
BASE Ø	.5597 REF
PITCH Ø	.7916 REF
MAJOR Ø	.850 - .859
FORM Ø	.835
MINOR Ø	.767 - .772
CIRCULAR SPACE WIDTH	.0764
EFFECTIVE SPACE WIDTH	.0738
MAX. DIMENSION BETWEEN TWO PINS	.6714
PIN Ø	.0800
SPLINE HARDNESS TO BE R/C 26-34	

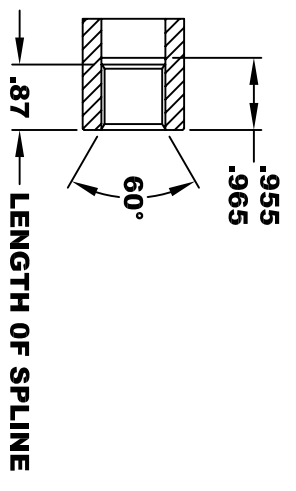

MOTOR WEIGHT: 53 LBS
CLASS "H" INSULATION
PERFORMANCE SPEC: 14

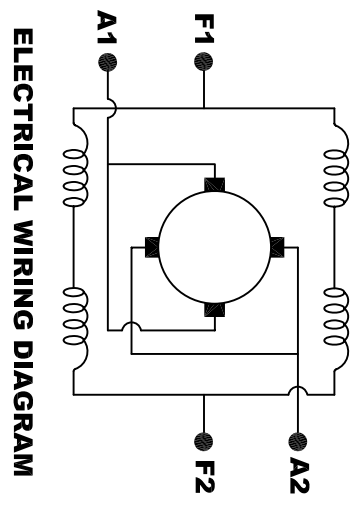

MOTOR WIRING CONNECTIONS:
CW ROTATION DRIVE END
CONNECT A1 & F1 TO ONE BATTERY TERMINAL
CONNECT A2 & F2 TO OTHER BATTERY TERMINAL
CCW ROTATION DRIVE END
SWITCH F1 & F2 CONNECTIONS

D & D MOTOR SYSTEMS INC
MOTOR OUTLINE

THIS PRINT IS THE PROPERTY OF D&D MOTOR SYSTEMS INC.
DO NOT SCALE
WORK TO DIMENSIONS
TOLERANCES UNLESS OTHERWISE SPECIFIED ARE AS FOLLOWS
.XX _____ .01
.XXX _____ .005
.XX ROUGH CASTING _____ .03
HOLES _____ -.001 / +.006
ANGLES _____ 0°30"

SIZE	DRAWN DATE	RELEASE DATE	DWG NO. / PART NO.	REV
B	5-6-05		ES-24F-14	R2
SCALE	STF	DRAWN BY	MJG	REV DATE
				2-13-13