

D&D MOTOR SYSTEMS INC.			
A2	SYRACUSE N.Y.		A1
S2	Model # ES-28-42		S1
Mfg. Date	Serial #	Rating	Voltage
XXXXXX	XXXX	CLASS H	36
MADE IN U.S.A.			

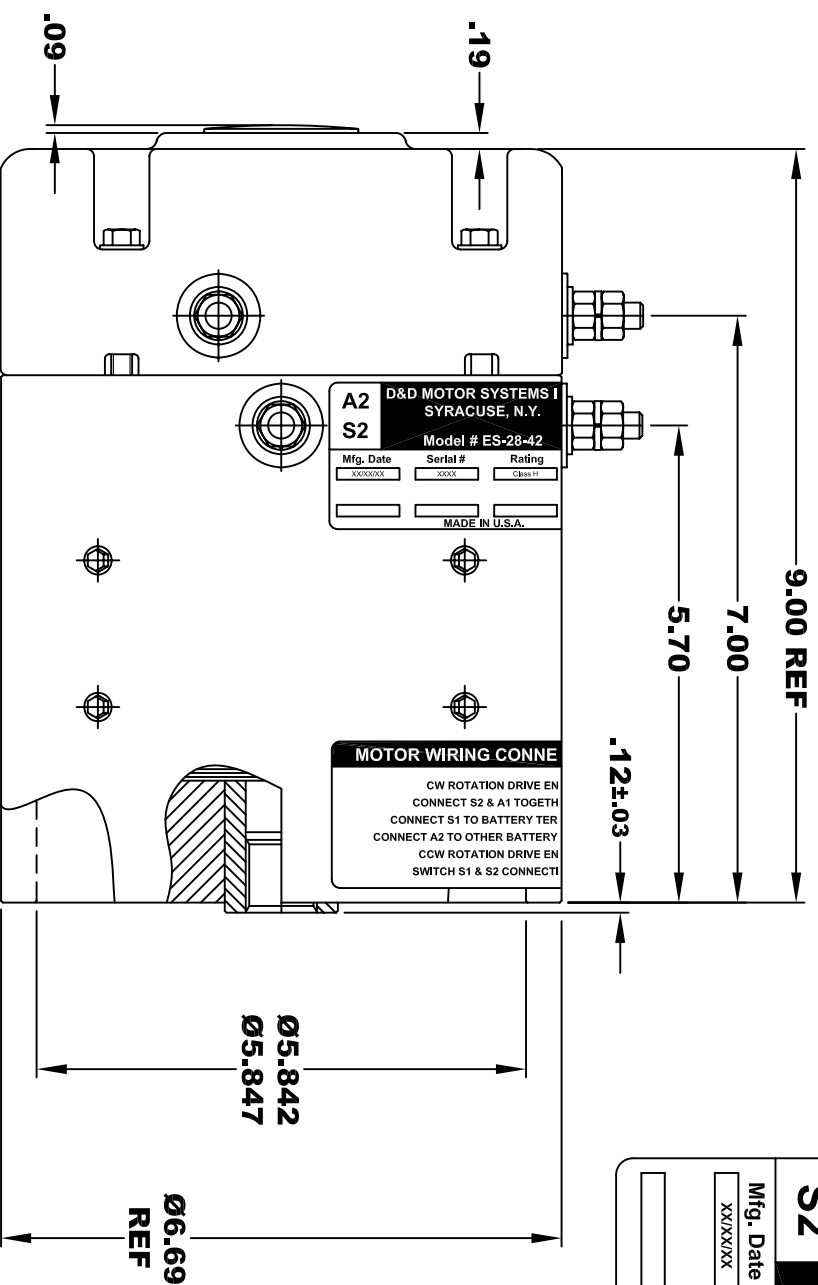

**TORQUE SPECIFICATION FOR
POWER CABLE SECURING TOP NUTS
5/16-18 UNC - 110 IN / LBS MAX**

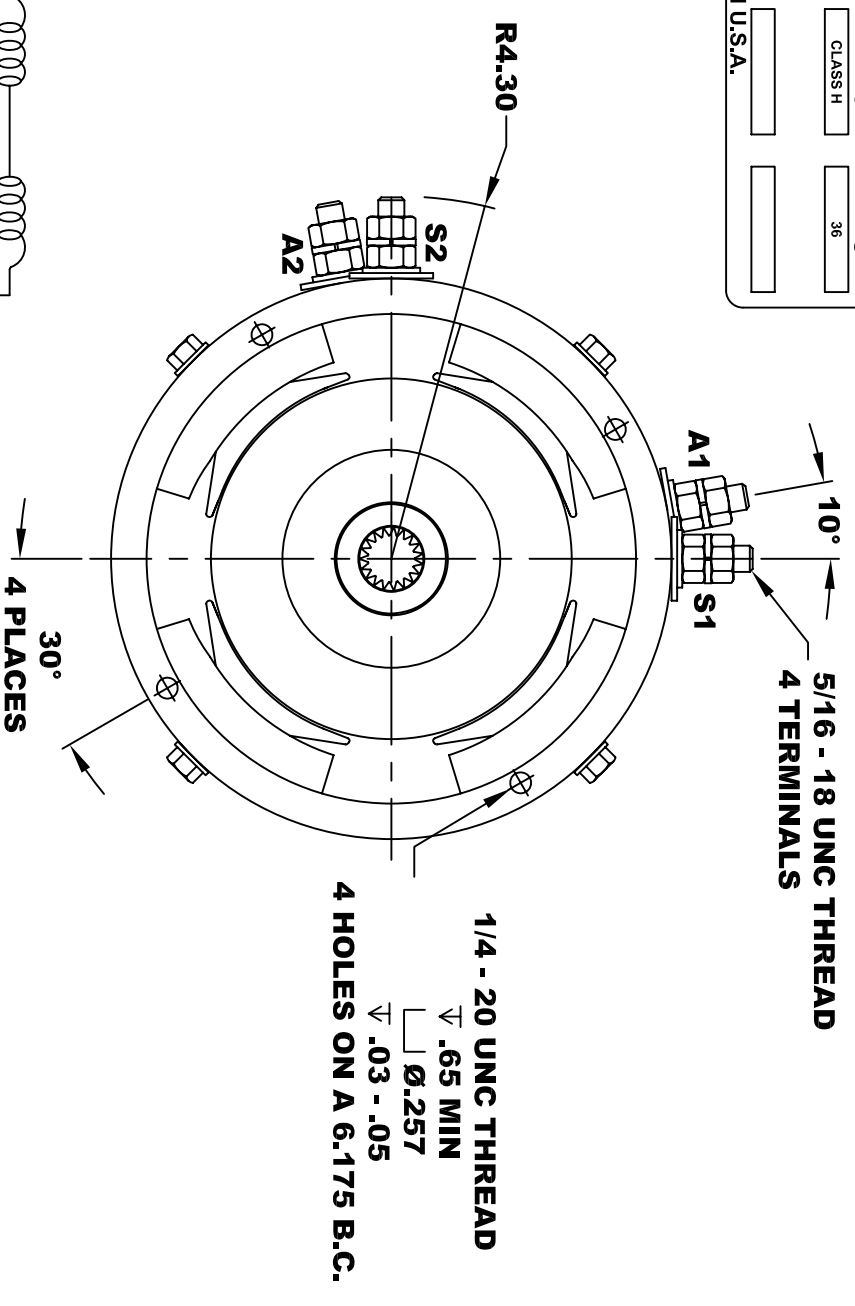

**INTERNAL INVOLUTE SPLINE SPECIFICATION
CLASS 5 FILET ROOT SIDE FIT (PER A.N.S.I. B92.1)**

NO. OF TEETH	19
SPLINE PITCH	24 / 48
PRESSURE ANGLE	45°
BASE Ø	.5597 REF
PITCH Ø	.7916 REF
MAJOR Ø	.850 - .859
FORM Ø	.835
MINOR Ø	.767 - .772
CIRCULAR SPACE WIDTH	.0764
EFFECTIVE SPACE WIDTH	.0738
MAX. DIMENSION BETWEEN	
TWO PINS	.6714
PIN Ø	.0800
SPLINE HARDNESS TO BE R/C	26-34

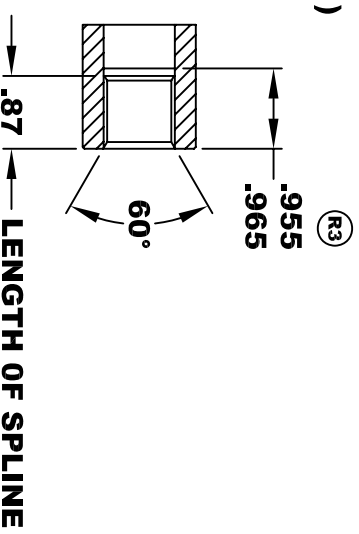

**MOTOR WEIGHT: 46 LBS
CLASS "H" INSULATION
PERFORMANCE SPEC: 42**

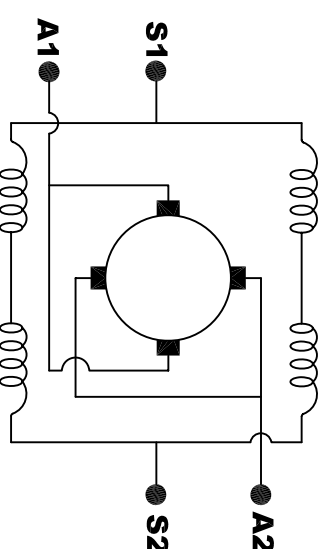

ELECTRICAL WIRING DIAGRAM

MOTOR WIRING CONNECTIONS:
CW ROTATION DRIVE END
 CONNECT S2 & A1 TOGETHER
 CONNECT S1 TO BATTERY TERMINAL
 CONNECT A2 TO OTHER BATTERY TERMINAL
CCW ROTATION DRIVE END
 SWITCH S1 & S2 CONNECTIONS

THIS PRINT IS THE PROPERTY OF D&D MOTOR SYSTEMS INC.
 DO NOT SCALE
 WORK TO DIMENSIONS
 TOLERANCES UNLESS OTHERWISE SPECIFIED ARE AS FOLLOWS
 .XX _____ .01
 .XXX _____ .005
 .XX ROUGH CASTING _____ .03
 HOLES _____ -.001 / +.006
 ANGLES _____ 0°30"

D & D MOTOR SYSTEMS INC

MOTOR OUTLINE

SIZE	DRAWN DATE	RELEASE DATE	DWG NO. / PART NO.	REV
B	7-23-04		ES-28-42 (R2)	R3
SCALE	STF	DRAWN BY	MJG	REV DATE
				1-12-06