

<b>D&amp;D MOTOR SYSTEMS INC.</b>			
<b>SYRACUSE N.Y.</b>			
<b>Model # ES-32-15</b>			
<b>A2</b>	<b>F2</b>	<b>A1</b>	<b>F1</b>
Mfg. Date	Serial #	Rating	Voltage
XXXX/XX	XXXX	Class H	36 / 48
MADE IN U.S.A.			

**TORQUE SPECIFICATION FOR  
POWER CABLE SECURING TOP NUTS**  
 5/16-18 UNC (A1 / A2) - 110 IN / LBS MAX  
 1/4-20 UNC (F1 / F2) - 50 IN / LBS MAX

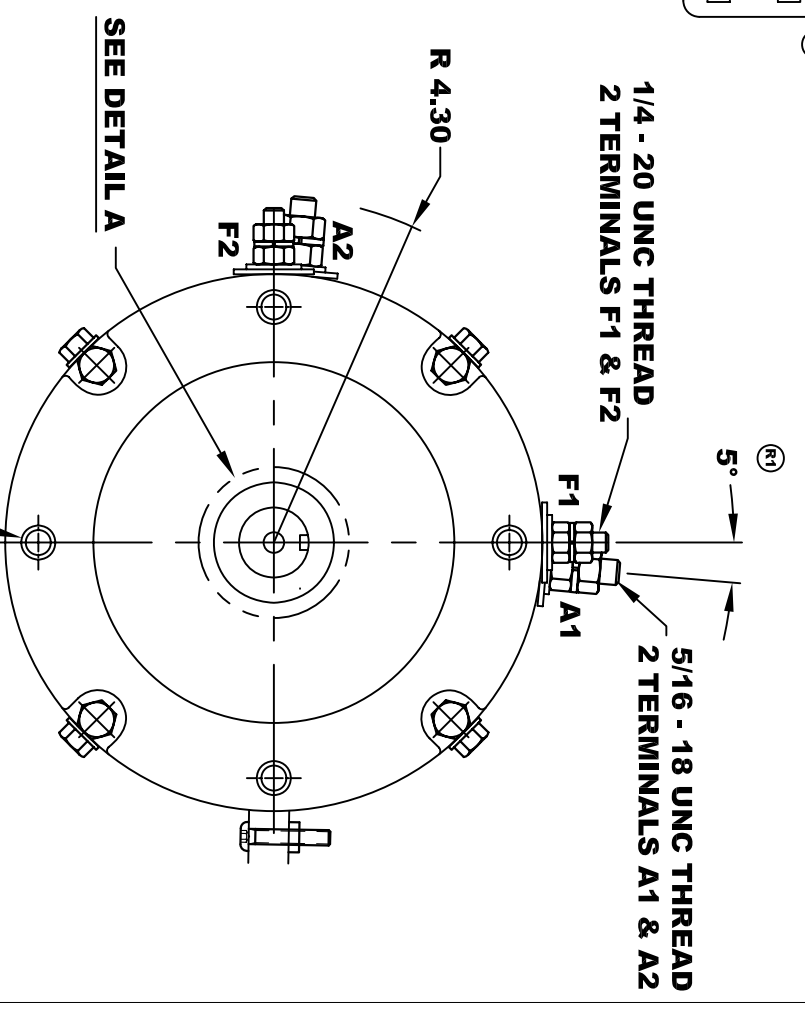

**3/8 - 16 UNC THREAD**  
 .65 MINIMUM  
 .03 -.05 x 45° CHAMFER  
 4 PLACES, ON A Ø5.875 B. C.



**MOTOR WEIGHT: 62 LBS**  
**CLASS "H" INSULATION**  
**PERFORMANCE SPEC: 15**

**(R4) REVISED VIEW**

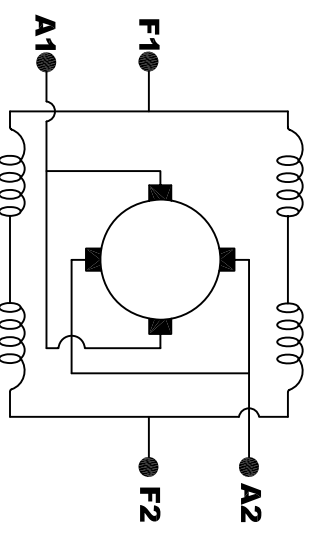

**ELECTRICAL WIRING DIAGRAM**

**MOTOR WIRING CONNECTIONS:**  
**CW ROTATION DRIVE END**  
 CONNECT A1 & F1 TO ONE BATTERY TERMINAL  
 CONNECT A2 & F2 TO OTHER BATTERY TERMINAL  
**CCW ROTATION DRIVE END**  
 SWITCH F1 & F2 CONNECTIONS

THIS PRINT IS THE PROPERTY OF D&D MOTOR SYSTEMS INC.  
 DO NOT SCALE  
 WORK TO DIMENSIONS  
 TOLERANCES UNLESS OTHERWISE SPECIFIED ARE AS FOLLOWS  
 .XX \_\_\_\_\_ .01  
 .XXX \_\_\_\_\_ .005  
 .XX ROUGH CASTING \_\_\_\_\_ .03  
 HOLES \_\_\_\_\_ -.001 / +.006  
 ANGLES \_\_\_\_\_ 0°30"

<b>D &amp; D MOTOR SYSTEMS INC</b>			
<b>MOTOR OUTLINE</b>			
SIZE	DRAWN DATE	RELEASE DATE	DWG NO. / PART NO.
B	8-22-02		ES-32-15 (R2)
SCALE	STF	DRAWN BY	MJG
			REV DATE
			4-5-06
			REV
			R4