

<b>D&amp;D MOTOR SYSTEMS INC.</b>			
<b>SYRACUSE N.Y.</b>			
<b>A2</b>	<b>F2</b>	<b>A1</b>	<b>F1</b>
<b>Model # ES-32B-15</b>			
Mfg. Date	Serial #	Rating	Voltage
XXXXXX	XXXX	CLASS -H	XX
MADE IN U.S.A.			

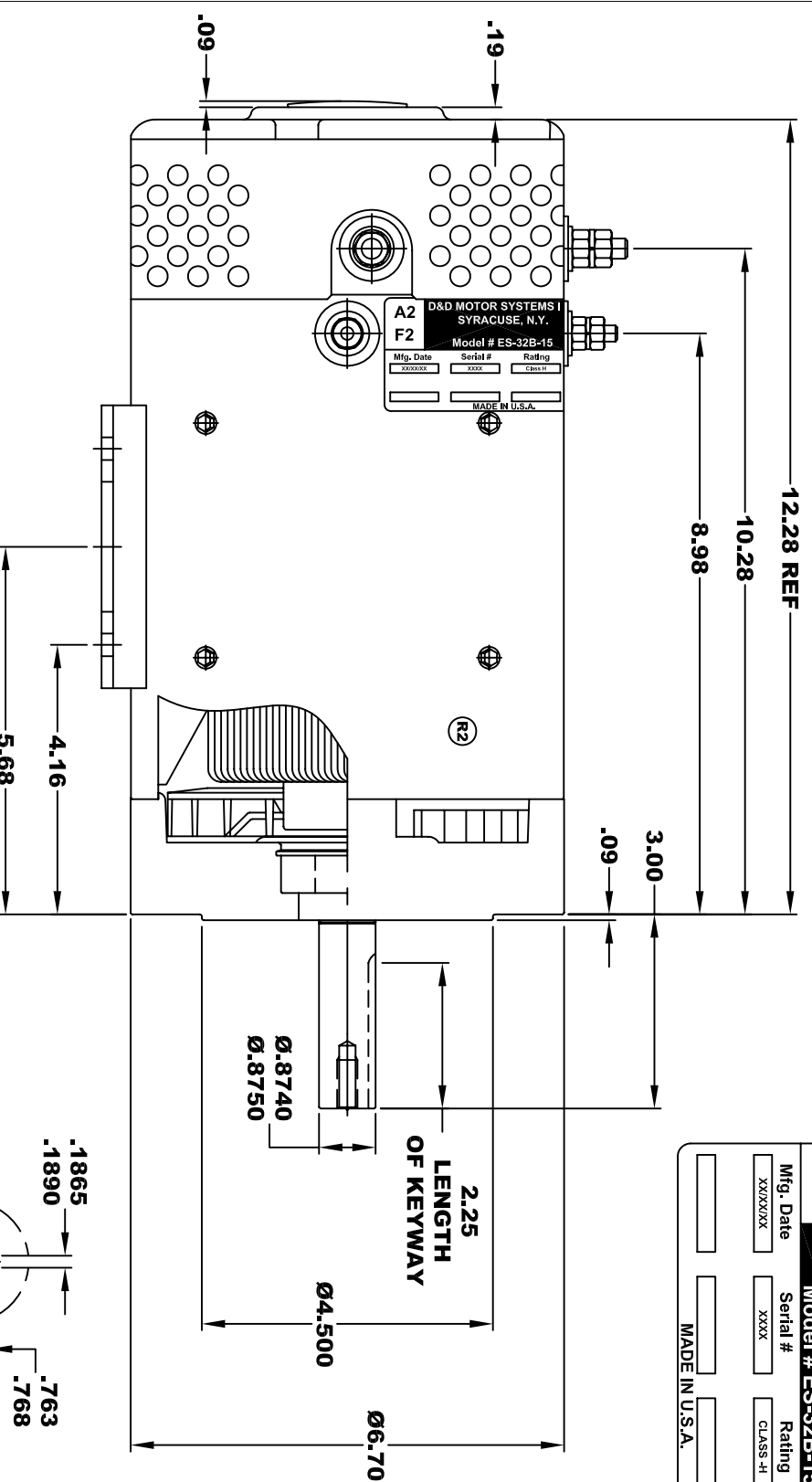

5/16 x 18 UNC THREAD  
 TYP .75

**DETAIL A**

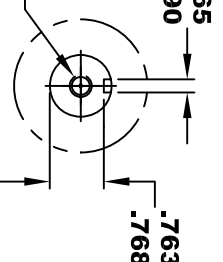

**TORQUE SPECIFICATION FOR  
 POWER CABLE SECURING TOP NUTS**  
 5/16-18 UNC (A1 / A2) - 110 IN / LBS MAX  
 1/4-20 UNC (F1 / F2) - 50 IN / LBS MAX

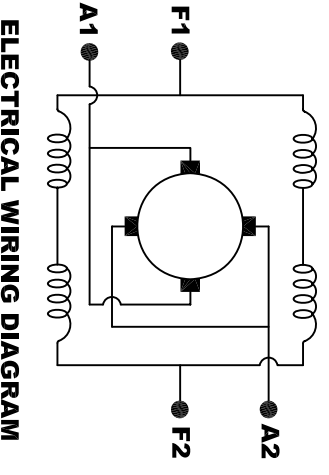
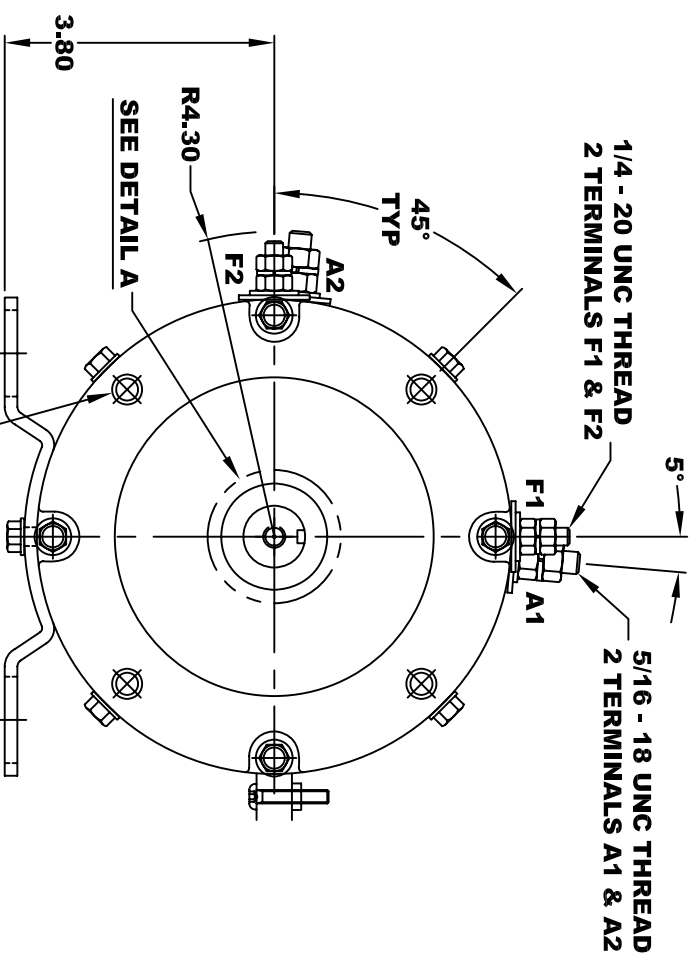

**MOTOR WIRING CONNECTIONS:**  
**CW ROTATION DRIVE END**  
 CONNECT A1 & F1 TO ONE BATTERY TERMINAL  
 CONNECT A2 & F2 TO OTHER BATTERY TERMINAL  
**CCW ROTATION DRIVE END**  
 SWITCH F1 & F2 CONNECTIONS

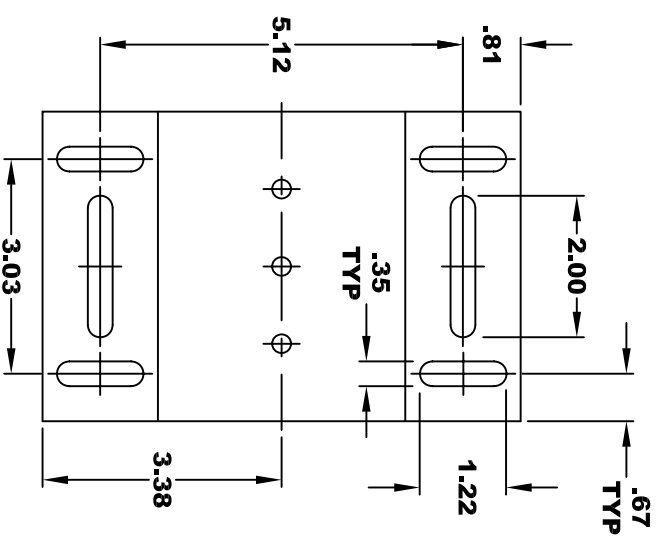

**MOTOR WEIGHT: 62 LBS**  
**CLASS "H" INSULATION**  
**PERFORMANCE SPEC: 15**

THIS PRINT IS THE PROPERTY OF D&D MOTOR SYSTEMS INC.  
 DO NOT SCALE  
 WORK TO DIMENSIONS  
 TOLERANCES UNLESS OTHERWISE SPECIFIED ARE AS FOLLOWS

.XX	.01
.XXX	.005
.XX ROUGH CASTING	.03
HOLES	-.001 / +.006
ANGLES	0°30"

**D & D MOTOR SYSTEMS INC**

**MOTOR OUTLINE**

SIZE	DRAWN DATE	RELEASE DATE	DWG NO. / PART NO.	REV
B	11-11-05		ES-32B-15	R2
SCALE	STF	DRAWN BY	MJG	REV DATE
				5-8-13