

D&D MOTOR SYSTEMS INC.				A1
SYRACUSE N.Y.				F1
Model # ES-49				
Mfg. Date	Serial #	Rating	Duty	
XXXXXX	XXXX	Class H	S240 MIN	
Voltage	Current	R.P.M.	H.P.	
XXXX	XXXX	XXXX	XXXX	
MADE IN U.S.A.				

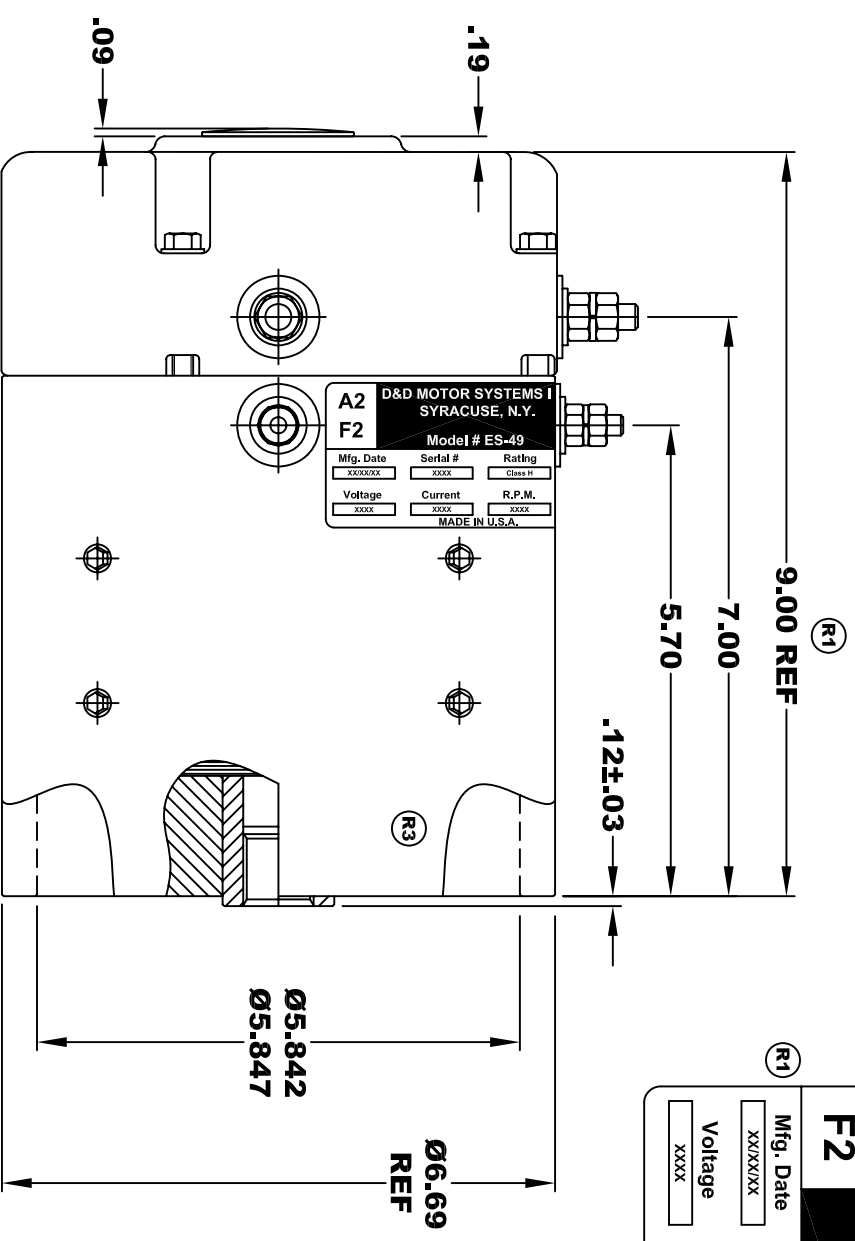

**TORQUE SPECIFICATION FOR
POWER CABLE SECURING TOP NUTS**
5/16-18 UNC (A1 / A2) - 110 IN / LBS MAX
1/4-20 UNC (F1 / F2) - 50 IN / LBS MAX

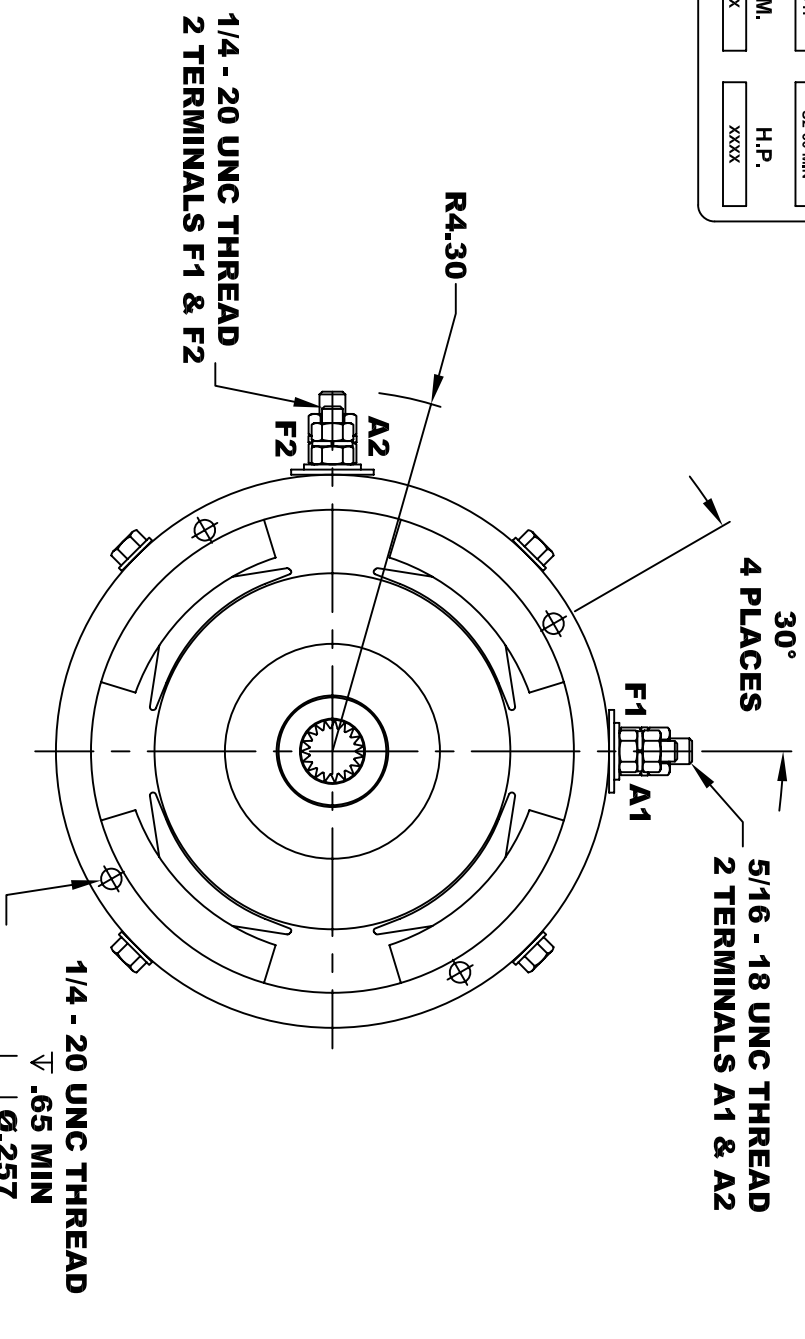

**INTERNAL INVOLUTE SPLINE SPECIFICATION
CLASS 5 FILLET ROOT SIDE FIT (PER A.N.S.I. B92.1)**

- NO. OF TEETH _____ 19
- SPLINE PITCH _____ 24 / 48
- PRESSURE ANGLE _____ 45°
- BASE Ø _____ .5597 REF
- PITCH Ø _____ .7916 REF
- MAJOR Ø _____ .850 - .859
- FORM Ø _____ .835
- MINOR Ø _____ .767 - .772
- CIRCULAR SPACE WIDTH _____ .0764
- EFFECTIVE SPACE WIDTH _____ .0738
- MAX. DIMENSION BETWEEN TWO PINS _____ .6714
- PIN Ø _____ .0800
- SPLINE HARDNESS TO BE R/C 26-34

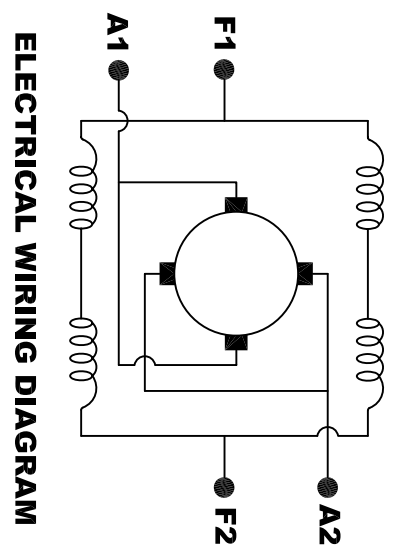
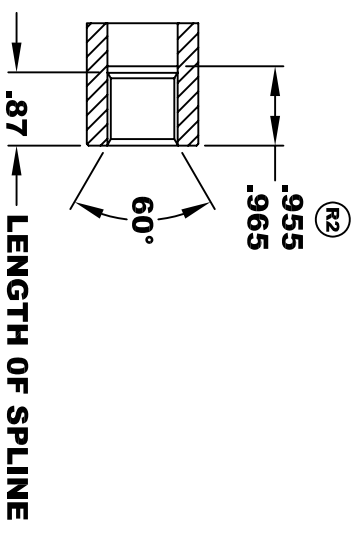

MOTOR WIRING CONNECTIONS:
CW ROTATION DRIVE END
CONNECT A1 & F1 TO ONE BATTERY TERMINAL
CONNECT A2 & F2 TO OTHER BATTERY TERMINAL
CCW ROTATION DRIVE END
SWITCH F1 & F2 CONNECTIONS

THIS PRINT IS THE PROPERTY OF D&D MOTOR SYSTEMS INC.
DO NOT SCALE
WORK TO DIMENSIONS
TOLERANCES UNLESS OTHERWISE SPECIFIED ARE AS FOLLOWS

.XX	_____	.01
.XXX	_____	.005
.XX ROUGH CASTING	_____	.03
HOLES	_____	-.001 / +.006
ANGLES	_____	0°30"

D & D MOTOR SYSTEMS INC			
MOTOR OUTLINE			
SIZE	DRAWN DATE	RELEASE DATE	DWG NO. / PART NO.
B	12-13-02		ES-49
SCALE	STF	DRAWN BY	MJG
		REV DATE	5-9-13