

A2	D&D MOTOR SYSTEMS INC.				A1
F2	SYRACUSE N.Y.				F1
Model # ES-63A		Rating	Class H	Duty	S2-60 MIN
Mfg. Date	Serial #	Current	R.P.M.	H.P.	XXXX
XXXXXX	XXXX	XXXX	XXXX	XXXX	
Voltage	XX	MADE IN U.S.A.			

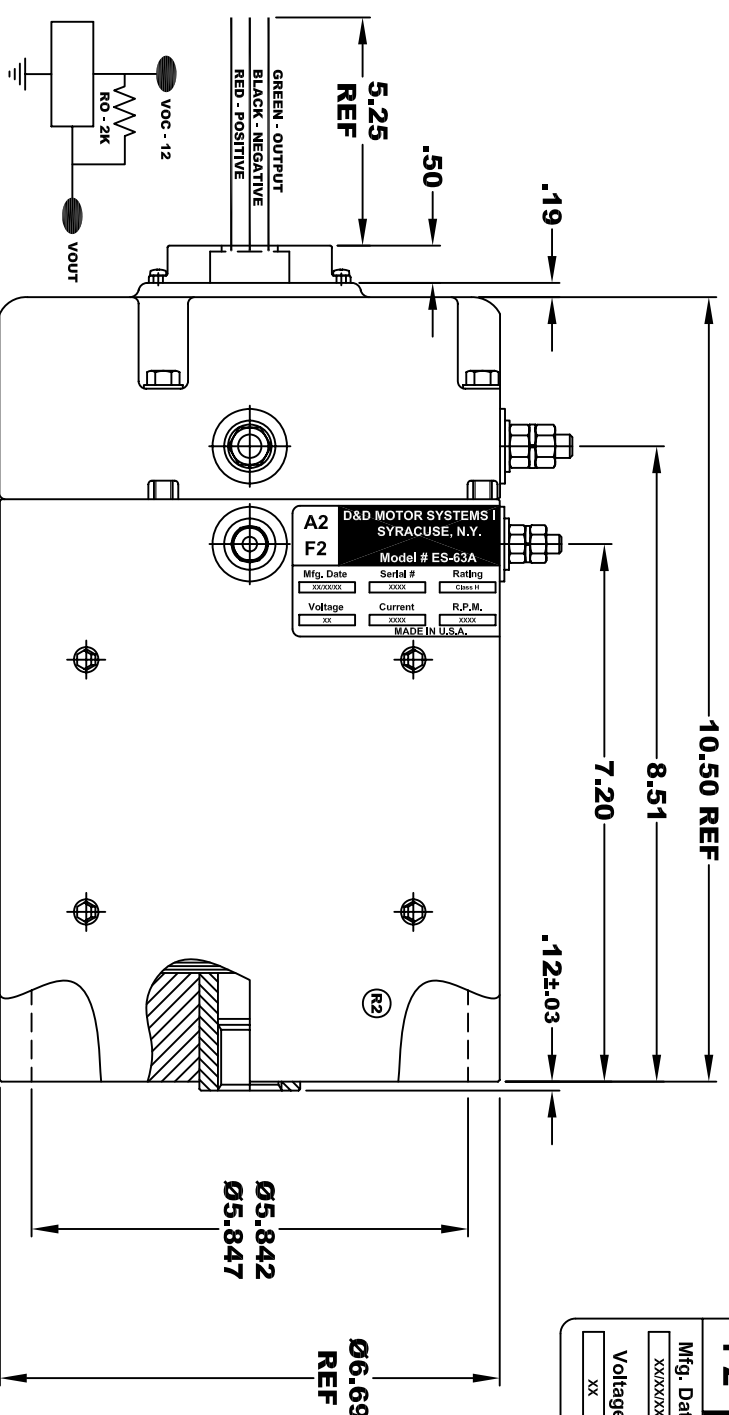

**TORQUE SPECIFICATION FOR
POWER CABLE SECURING TOP NUTS**
5/16-18 UNC (A1 / A2) - 110 IN / LBS MAX
1/4-20 UNC (F1 / F2) - 50 IN / LBS MAX

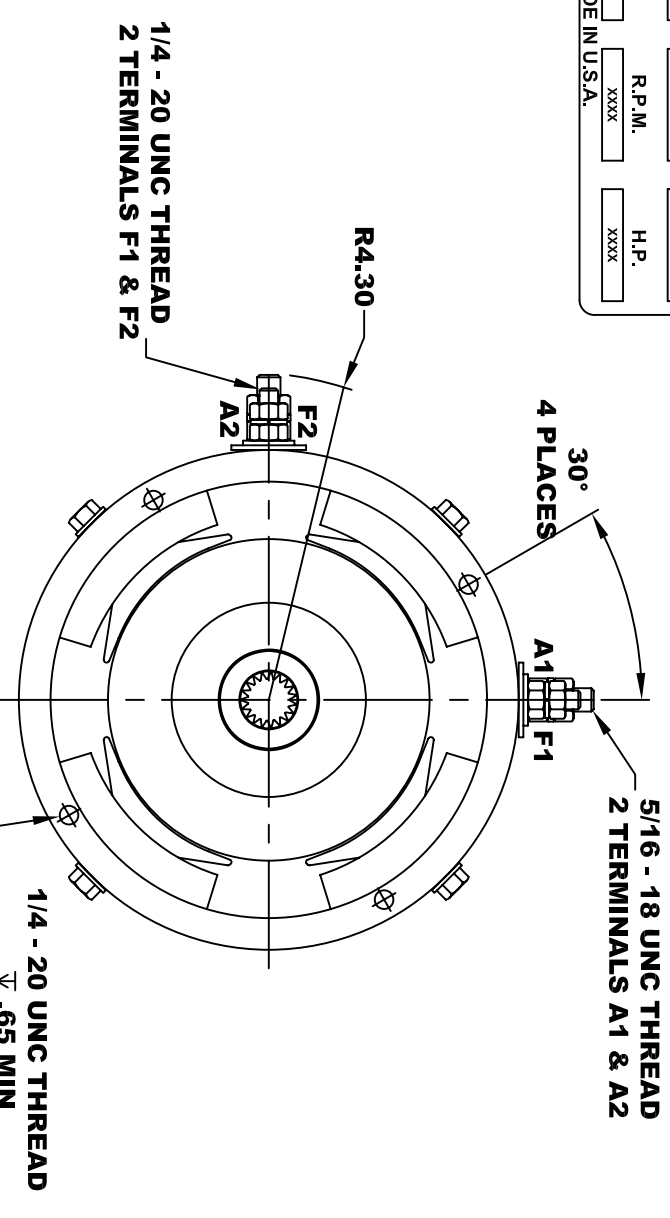

ELECTRICAL SPECIFICATION:
-4.5V TO 24V OPERATING VOLTAGE
-20°C TO 85°C OPERATING TEMPERATURE
-CURRENT SINKING UP TO 25mA
-AN EXTERNAL PULL UP RESISTOR IS REQUIRED
-SENSOR IS DESIGNED TO OPERATE WITH 4 N/S POLEPAIRS
-THE OPERATIONAL DISTANCE BETWEEN THE MAGNET
AND THE HOUSING, INCLUDING ANY RUNOUT
SHOULD NOT EXCEED .030 INCHES

**INTERNAL INVOLUTE SPLINE SPECIFICATION
CLASS 5 FILLET ROOT SIDE FIT (PER A.N.S.I. B92.1)**

NO. OF TEETH _____ 19
SPLINE PITCH _____ 24 / 48
PRESSURE ANGLE _____ 45°
BASE Ø _____ .5597 REF
PITCH Ø _____ .7916 REF
MAJOR Ø _____ .850 - .859
FORM Ø _____ .835
MINOR Ø _____ .767 - .772
CIRCULAR SPACE WIDTH _____ .0764
EFFECTIVE SPACE WIDTH _____ .0738
MAX. DIMENSION BETWEEN
TWO PINS _____ .6714
PIN Ø _____ .0800
SPLINE HARDNESS TO BE R/C 26-34

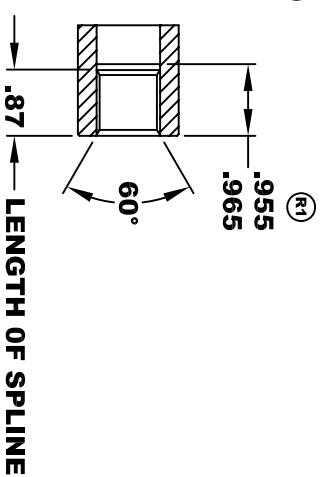

MOTOR WEIGHT: 57 LBS
CLASS "H" INSULATION
PERFORMANCE SPEC: 32

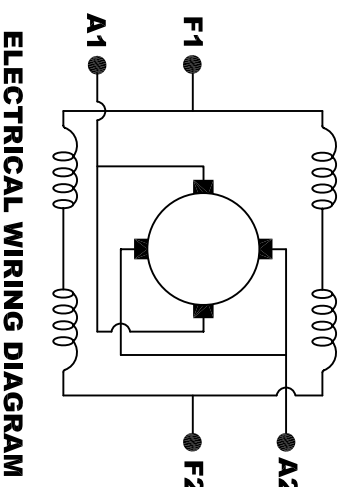

ELECTRICAL WIRING DIAGRAM

MOTOR WIRING CONNECTIONS:

CW ROTATION DRIVE END
CONNECT A1 & F1 TO ONE BATTERY TERMINAL
CONNECT A2 & F2 TO OTHER BATTERY TERMINAL
CCW ROTATION DRIVE END
SWITCH F1 & F2 CONNECTIONS

D & D MOTOR SYSTEMS INC

MOTOR OUTLINE

THIS PRINT IS THE PROPERTY OF D&D MOTOR SYSTEMS INC.
DO NOT SCALE
WORK TO DIMENSIONS
TOLERANCES UNLESS OTHERWISE SPECIFIED ARE AS FOLLOWS
.XXX _____ .005
.XX _____ .01
.XX ROUGH CASTING _____ .03
HOLES _____ -.001 / +.006
ANGLES _____ 0°30"

SIZE	DRAWN DATE	RELEASE DATE	DWG NO. / PART NO.	REV
B	11-14-03		ES-63A	R2
SCALE	STF	DRAWN BY	MJG	REV DATE
				5-13-13