

D&D MOTOR SYSTEMS INC.			
A2		A1	
SYRACUSE N.Y.			
F2		F1	
Model # ES-65G-14			
Mfg. Date	Serial #	Rating	Voltage
XXXX/XX	XXXX	Class H	XX
MADE IN U.S.A.			

**TORQUE SPECIFICATION FOR
POWER CABLE SECURING TOP NUTS**
5/16-18 UNC (A1 / A2) - 110 IN LBS MAX
1/4-20 UNC (F1 / F2) - 50 IN LBS MAX

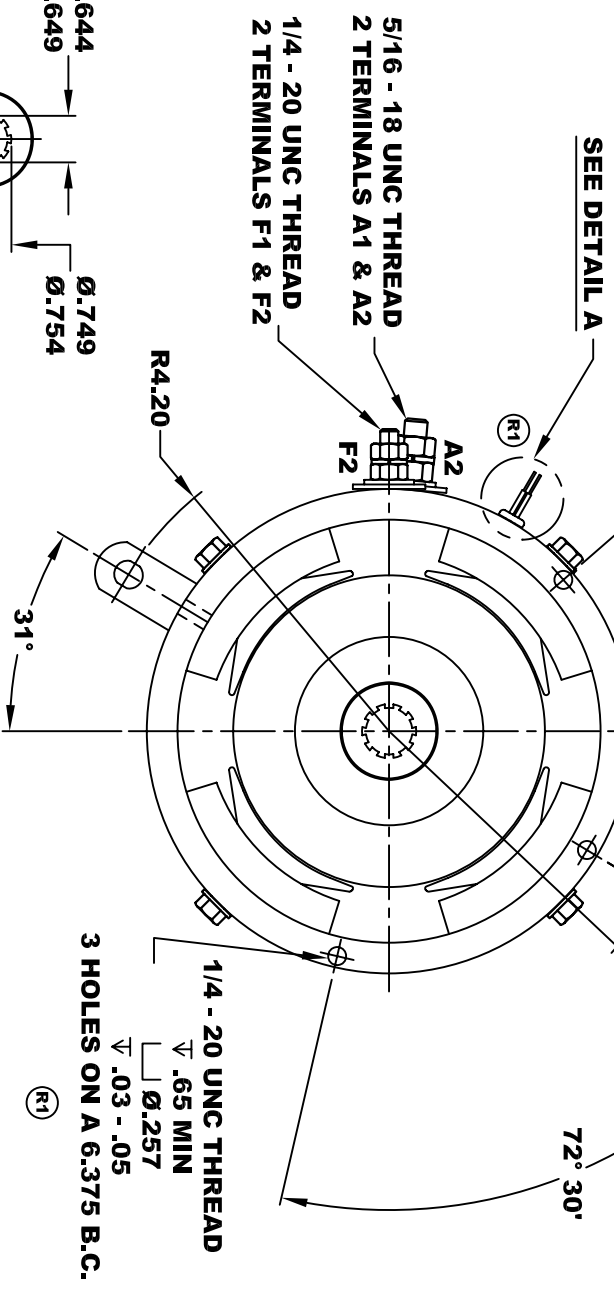
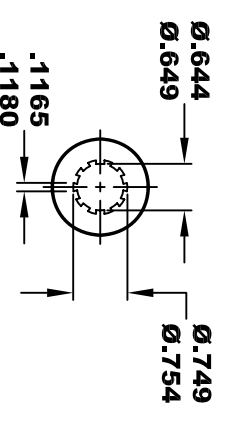
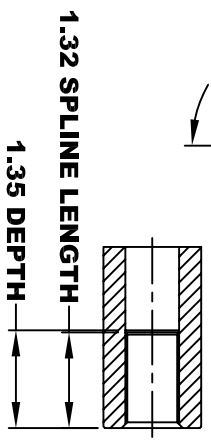
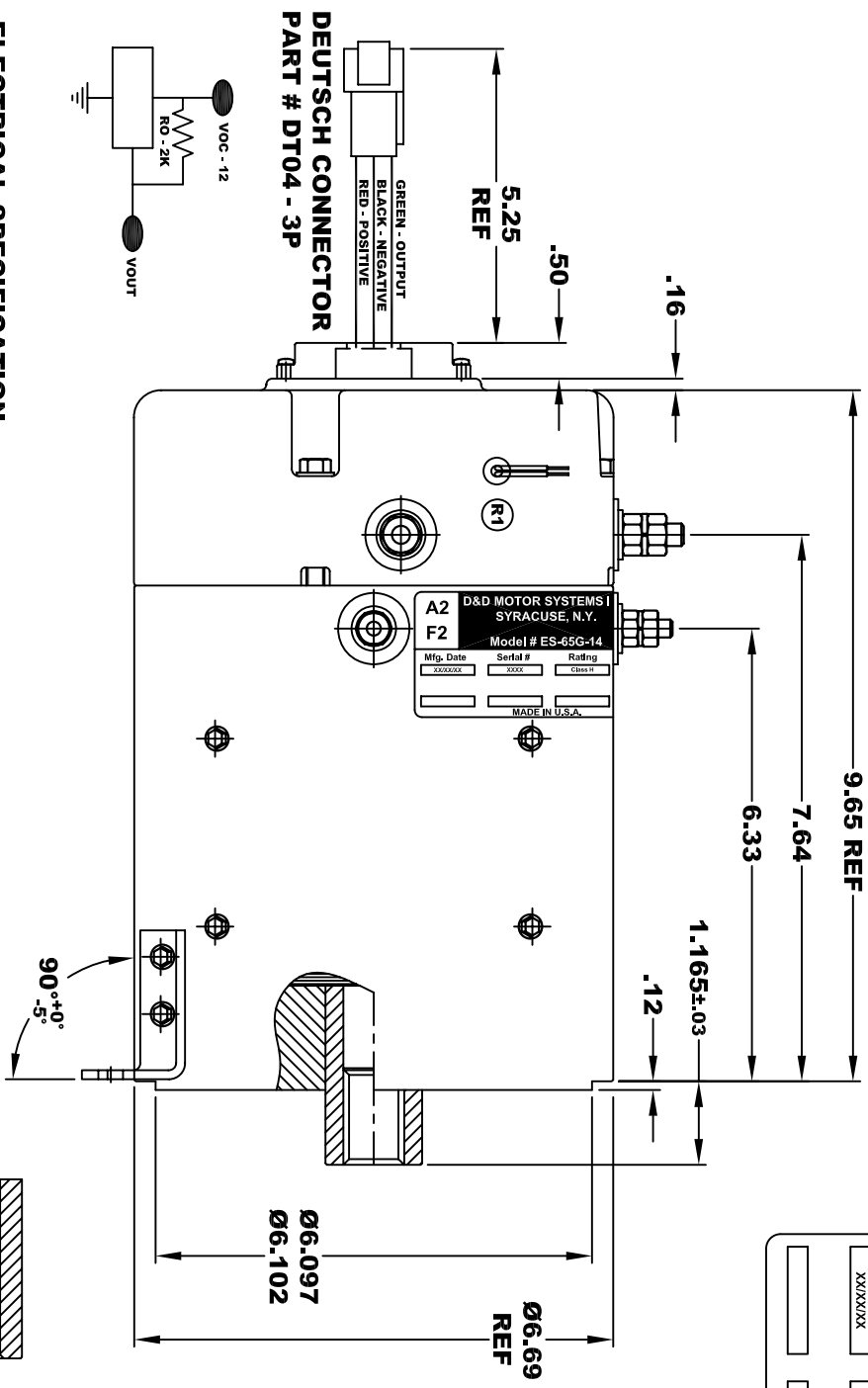

ELECTRICAL SPECIFICATION:
-4.5V TO 24V OPERATING VOLTAGE
-20° C TO 85° C OPERATING TEMPERATURE
-CURRENT SINKING UP TO 25mA
-AN EXTERNAL OUTPUT PULL UP RESISTOR IS REQUIRED
-SENSOR IS DESIGNED TO OPERATE WITH 4 N/S POLEPAIRS
-THE OPERATIONAL DISTANCE BETWEEN THE MAGNET
AND THE HOUSING, INCLUDING ANY RUNOUT
SHOULD NOT EXCEED .030 INCHES

MOTOR WEIGHT 53 LBS
CLASS "H" INSULATION
PERFORMANCE SPEC: 14

THERMAL PROTECTOR ELECTRICAL SPECIFICATION:
MAX. DC OPERATING VOLTAGE: 60 VOLTS
140° C NORMALLY CLOSED SWITCH

DETAIL A

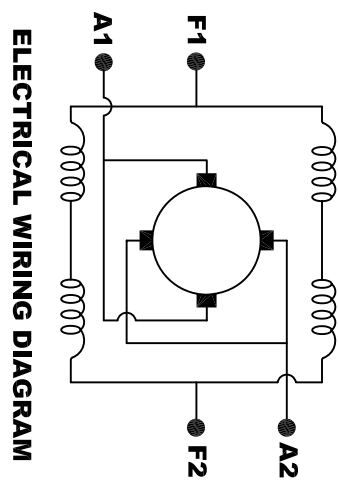

MOTOR WIRING CONNECTIONS:
CW ROTATION DRIVE END
CONNECT A1 & F1 TO ONE BATTERY TERMINAL
CONNECT A2 & F2 TO OTHER BATTERY TERMINAL
CCW ROTATION DRIVE END
SWITCH F1 & F2 CONNECTIONS

THIS PRINT IS THE PROPERTY OF D&D MOTOR SYSTEMS INC.
DO NOT SCALE
WORK TO DIMENSIONS
TOLERANCES UNLESS OTHERWISE SPECIFIED ARE AS FOLLOWS
.XX _____ .01
.XXX _____ .005
.XX ROUGH CASTING _____ .03
HOLES _____ -.001 / +.006
ANGLES _____ 0°30"

D & D MOTOR SYSTEMS INC			
MOTOR OUTLINE			
SIZE	DRAWN DATE	RELEASE DATE	DWG NO. / PART NO.
B	4-21-09		ES-65G-14
SCALE	STF	DRAWN BY	MJG
			REV DATE
			R1 5-14-09