

D&D MOTOR SYSTEMS INC.			
SYRACUSE N.Y.			
A2	F2	A1	F1
Model # ES-66D-33			
Mfg. Date	Serial #	Rating	Voltage
XX/XX/XX	XXXX	CLASS-H	XX
MADE IN U.S.A.			

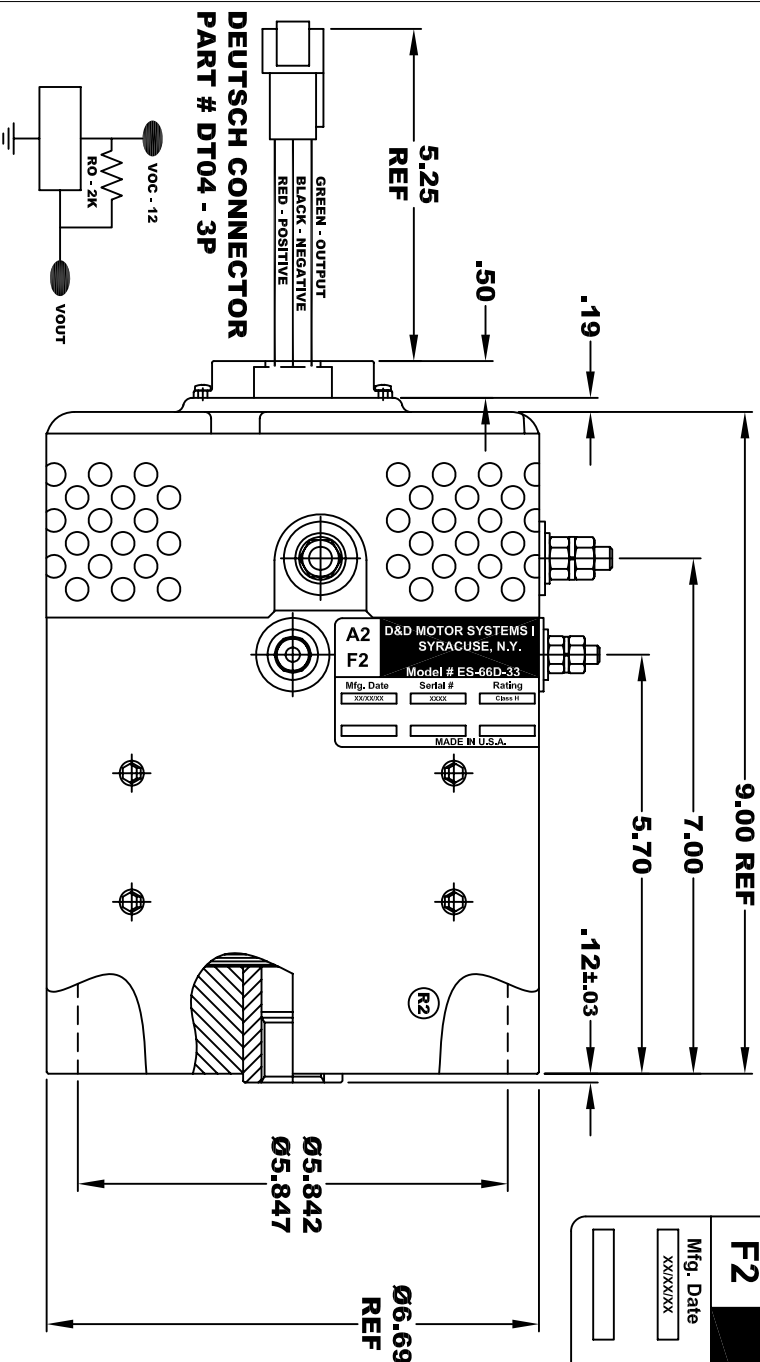

ELECTRICAL SPECIFICATION:
 -4.5V TO 24V OPERATING VOLTAGE
 -20°C TO 85°C OPERATING TEMPERATURE
 -CURRENT SINKING UP TO 25mA
 -AN EXTERNAL OUTPUT PULL UP RESISTOR IS REQUIRED
 -SENSOR IS DESIGNED TO OPERATE WITH 4 N/S POLEPAIRS
 -THE OPERATIONAL DISTANCE BETWEEN THE MAGNET
 AND THE HOUSING, INCLUDING ANY RUNOUT
 SHOULD NOT EXCEED .030 INCHES

INTERNAL INVOLUTE SPLINE SPECIFICATION
 CLASS 5 FILLET ROOT SIDE FIT (PER A.N.S.I. B92.1)

NO. OF TEETH _____ 19
 SPLINE PITCH _____ 24 / 48
 PRESSURE ANGLE _____ 45°
 BASE Ø _____ .5597 REF
 PITCH Ø _____ .7916 REF
 MAJOR Ø _____ .850 - .859
 FORM Ø _____ .835
 MINOR Ø _____ .767 - .772
 CIRCULAR SPACE WIDTH _____ .0764
 EFFECTIVE SPACE WIDTH _____ .0738
 MAX. DIMENSION BETWEEN
 TWO PINS _____ .6714
 PIN Ø _____ .0800
 SPLINE HARDNESS TO BE R/C 26-34

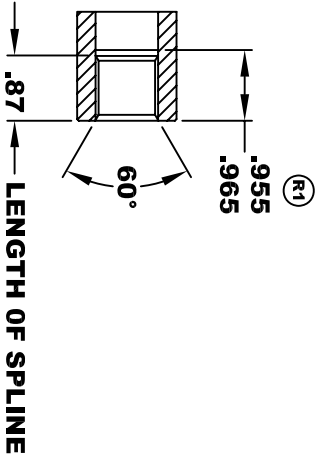

MOTOR WEIGHT 46 LBS
 CLASS "H" INSULATION
 PERFORMANCE SPEC: 33

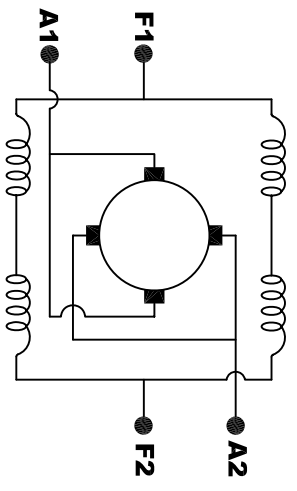
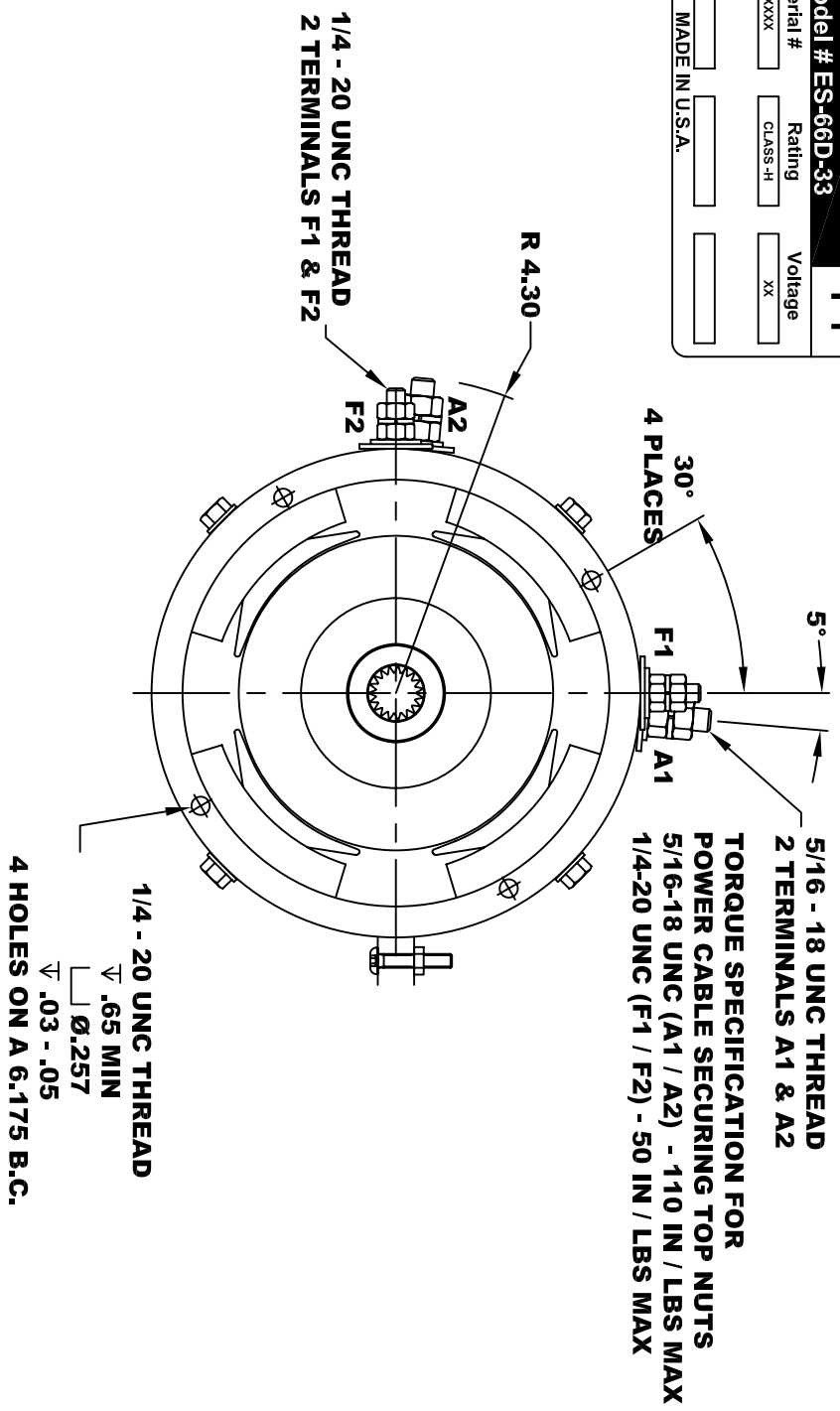

ELECTRICAL WIRING DIAGRAM

MOTOR WIRING CONNECTIONS:
 CW ROTATION DRIVE END
 CONNECT A1 & F1 TO ONE BATTERY TERMINAL
 CONNECT A2 & F2 TO OTHER BATTERY TERMINAL
 CCW ROTATION DRIVE END
 SWITCH F1 & F2 CONNECTIONS

D & D MOTOR SYSTEMS INC

MOTOR OUTLINE

THIS PRINT IS THE PROPERTY OF D&D MOTOR SYSTEMS INC.
 DO NOT SCALE
 WORK TO DIMENSIONS
 TOLERANCES UNLESS OTHERWISE SPECIFIED ARE AS FOLLOWS
 .XX _____ .01
 .XXX _____ .005
 .XX ROUGH CASTING _____ .03
 HOLES _____ -.001 / +.006
 ANGLES _____ 0°30"

SIZE	DRAWN DATE	RELEASE DATE	DWG NO. / PART NO.	REV
B	7-20-05		ES-66D-33	R2
SCALE	STF	DRAWN BY	MJG	REV DATE
				5-14-13