

**TORQUE SPECIFICATION FOR
POWER CABLE SECURING TOP NUTS
5/16-18 UNC - 110 IN / LBS MAX**

A2		D&D MOTOR SYSTEMS INC.		A1	
S2		SYRACUSE N.Y.		S1	
Model # ES-82					
Mfg. Date	Serial #	Rating	Duty		
XXXX/XX	XXXX	CLASS -H	S2-30 MIN		
Voltage	Current	R.P.M.	H.P.		
36 / 48	92 / 80	3550 / 5050	3.3 / 3.9		
MADE IN U.S.A.					

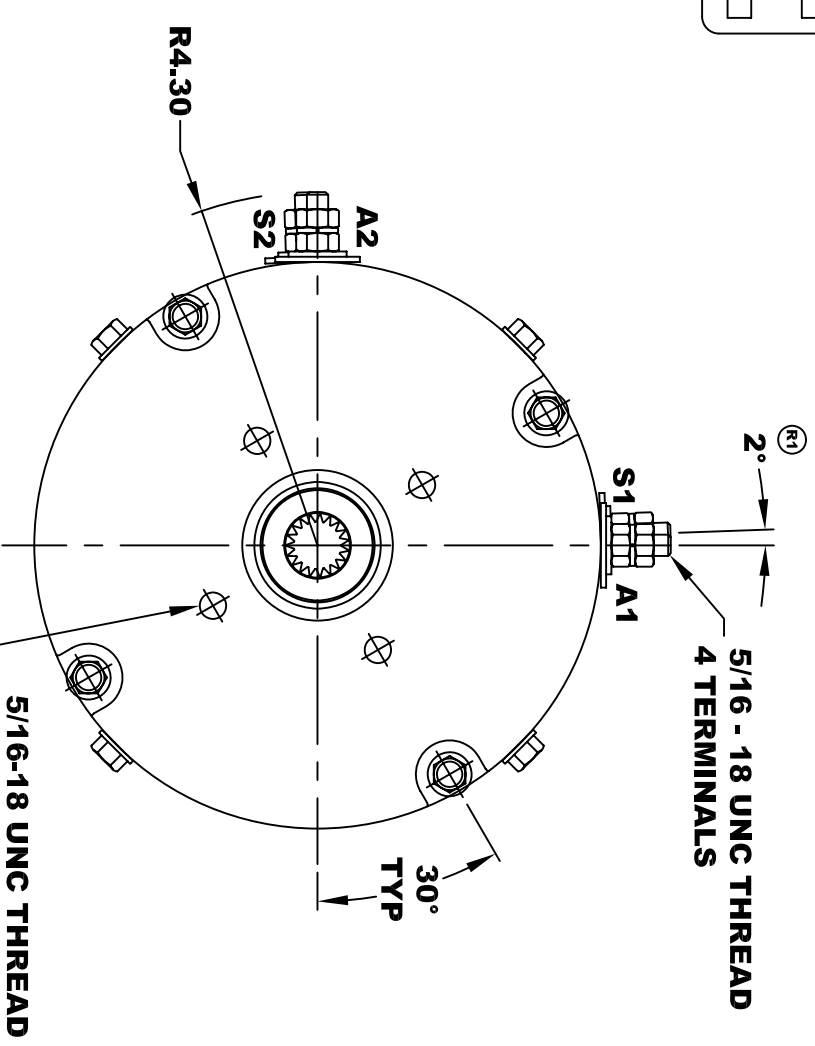
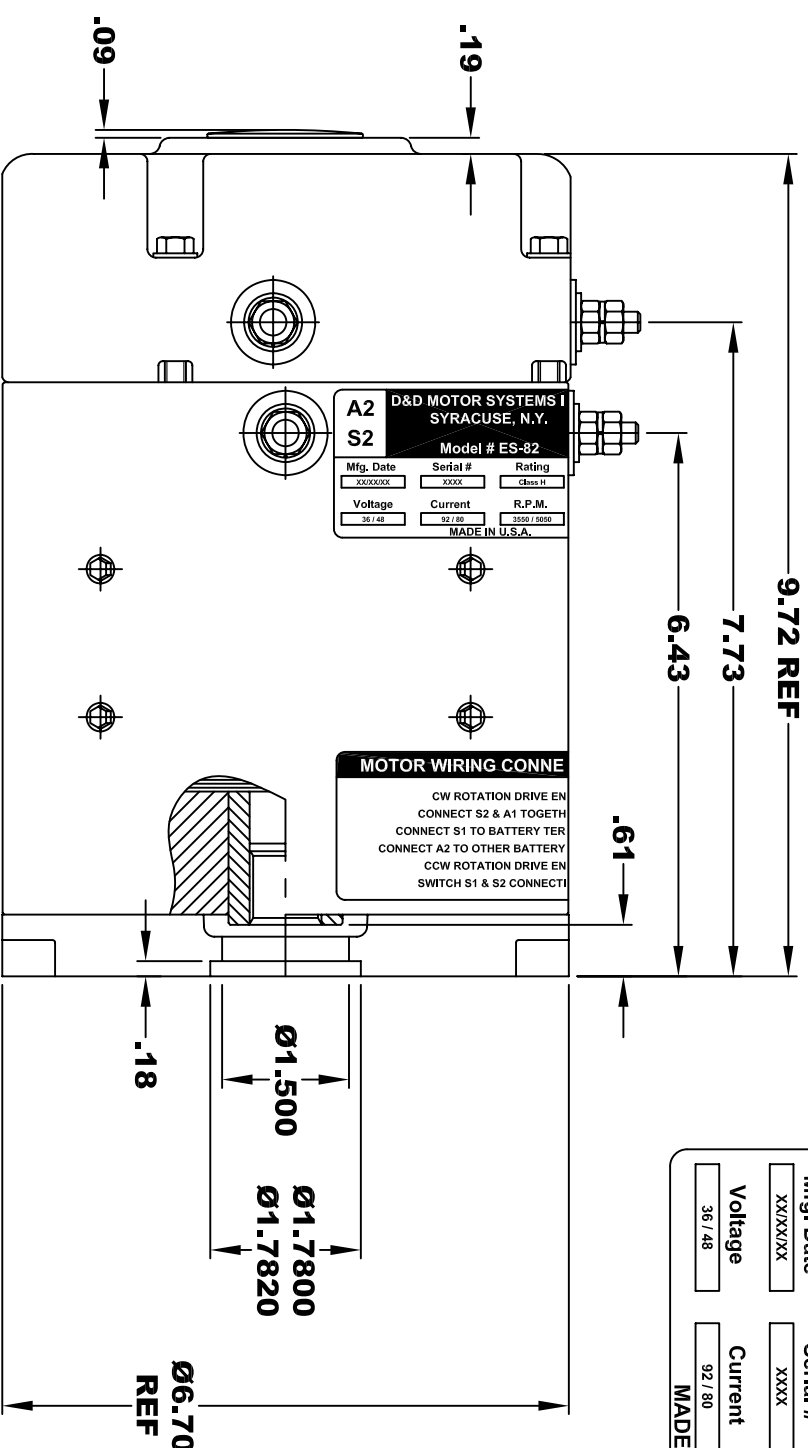

**INTERNAL INVOLUTE SPLINE SPECIFICATION
CLASS 5 FILLET ROOT SIDE FIT (PER A.N.S.I. B92.1)**

NO. OF TEETH	19
SPLINE PITCH	24 / 48
PRESSURE ANGLE	45°
BASE Ø	.5597 REF
PITCH Ø	.7916 REF
MAJOR Ø	.850 - .859
FORM Ø	.835
MINOR Ø	.767 - .772
CIRCULAR SPACE WIDTH	.0764
EFFECTIVE SPACE WIDTH	.0738
MAX. DIMENSION BETWEEN	
TWO PINS	.6714
PIN Ø	.0800
SPLINE HARDNESS TO BE R/C 26-34	

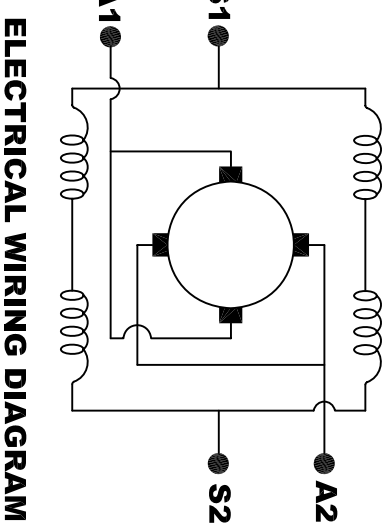
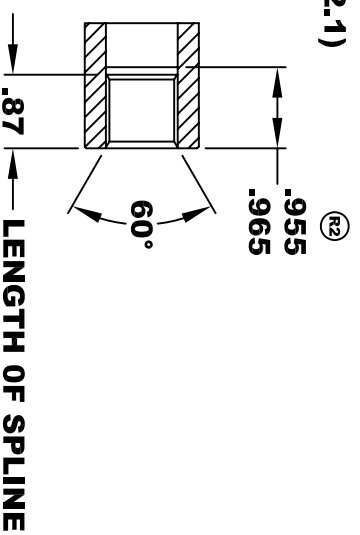

ELECTRICAL WIRING DIAGRAM

**MOTOR WIRING CONNECTIONS:
CW ROTATION DRIVE END
CONNECT S2 & A1 TOGETHER
CONNECT S1 TO BATTERY TERMINAL
CONNECT A2 TO OTHER BATTERY TERMINAL
CCW ROTATION DRIVE END
SWITCH S1 & S2 CONNECTIONS**

D & D MOTOR SYSTEMS INC

MOTOR OUTLINE

THIS PRINT IS THE PROPERTY OF D&D MOTOR SYSTEMS INC.
DO NOT SCALE
WORK TO DIMENSIONS
TOLERANCES UNLESS OTHERWISE SPECIFIED ARE AS FOLLOWS
.XX _____ .01
.XXX _____ .005
.XX ROUGH CASTING _____ .03
HOLES _____ -.001 / +.006
ANGLES _____ 0°30"

SIZE	DRAWN DATE	RELEASE DATE	DWG NO. / PART NO.	REV
B	8-18-02		ES-82	R2
SCALE	STF	DRAWN BY	MJG	REV DATE
				2-1-06