

D&D MOTOR SYSTEMS INC.		A1	
SYRACUSE N.Y.		A2	
Model # ES-93A-33		F1	
Mfg. Date	Serial #	Rating	Voltage
XX/XX/XX	XXXX	CLASS -H	24 / 36 / 48
MADE IN U.S.A.			

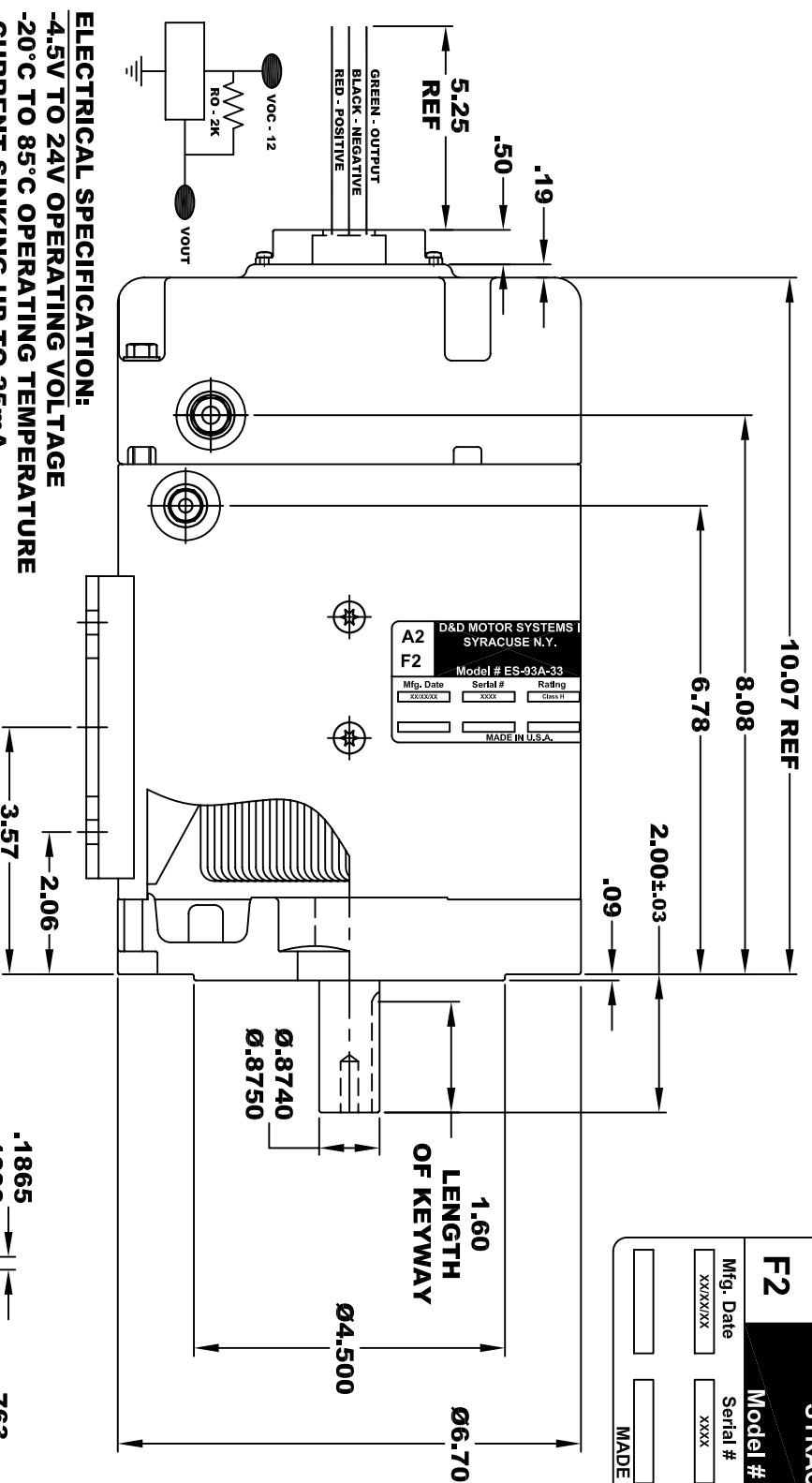

ELECTRICAL SPECIFICATION:
 -4.5V TO 24V OPERATING VOLTAGE
 -20°C TO 85°C OPERATING TEMPERATURE
 -CURRENT SINKING UP TO 25mA
 -AN EXTERNAL OUTPUT PULL UP RESISTOR IS REQUIRED
 -SENSOR IS DESIGNED TO OPERATE WITH 4 N/S POLEPAIRS
 -THE OPERATIONAL DISTANCE BETWEEN THE MAGNET
 -AND THE HOUSING, INCLUDING ANY RUNOUT
 -SHOULD NOT EXCEED .030 INCHES

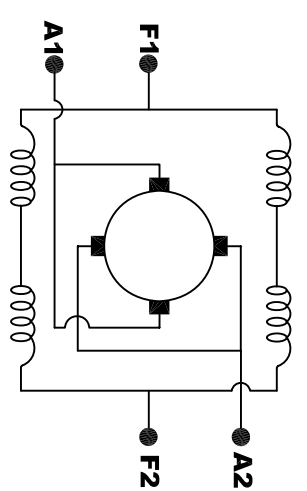

ELECTRICAL WIRING DIAGRAM

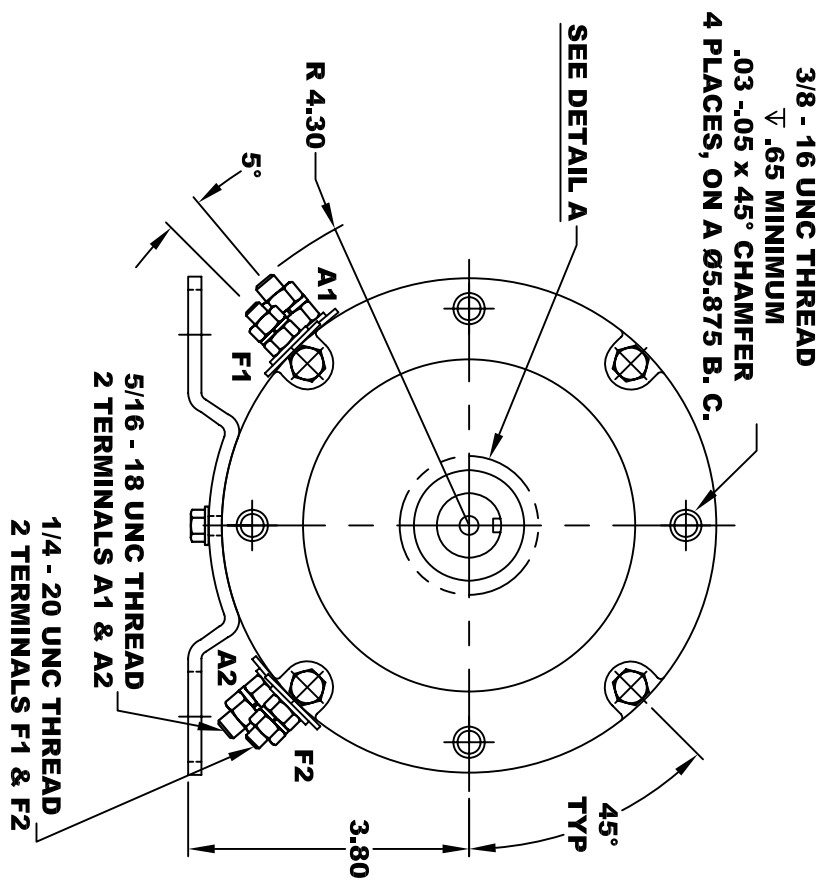

**TORQUE SPECIFICATION FOR
 POWER CABLE SECURING TOP NUTS**
 5/16-18 UNC (A1 / A2) - 110 IN / LBS MAX
 1/4-20 UNC (F1 / F2) - 50 IN / LBS MAX

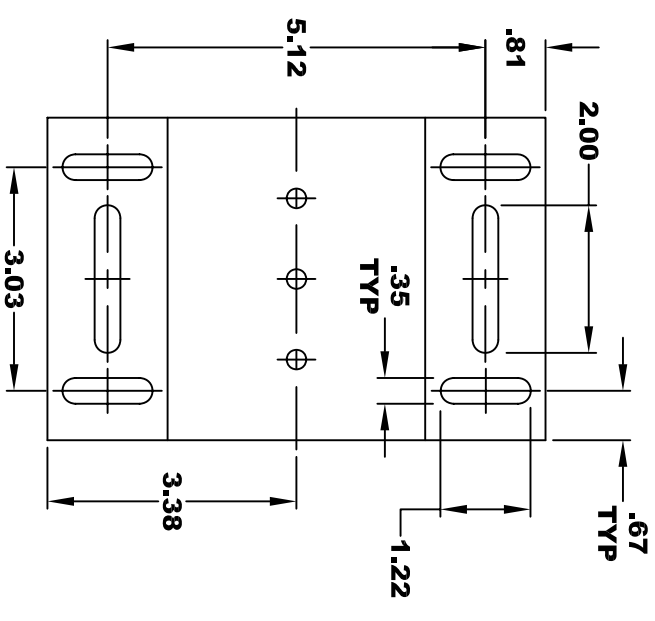

MOTOR WEIGHT: 53 LBS
CLASS "H" INSULATION
PERFORMANCE SPEC: 33

THIS PRINT IS THE PROPERTY OF D&D MOTOR SYSTEMS INC.
 DO NOT SCALE
 WORK TO DIMENSIONS
 TOLERANCES UNLESS OTHERWISE SPECIFIED ARE AS FOLLOWS
 .XX _____ .01
 .XXX _____ .005
 .XX ROUGH CASTING _____ .03
 HOLES _____ -.001 / +.006
 ANGLES _____ 0°30"

D & D MOTOR SYSTEMS INC			
MOTOR OUTLINE			
SIZE	DRAWN DATE	RELEASE DATE	DWG NO. / PART NO.
B	3-2-04		ES-93A-33
SCALE	STF	DRAWN BY	MJG
			REV DATE