

<b>D&amp;D MOTOR SYSTEMS INC.</b>			
<b>SYRACUSE N.Y.</b>			
<b>A2</b>	<b>F2</b>	<b>Model # ES-94A-7</b>	<b>A1</b>
Mfg. Date	Serial #	Rating	Voltage
XXXXXX	XXXX	Class H	XX
MADE IN U.S.A.			

**TORQUE SPECIFICATION FOR  
POWER CABLE SECURING TOP NUTS**  
**3/8-16 UNC (A1 / A2) - 140 IN / LBS MAX**  
**1/4-20 UNC (F1 / F2) - 50 IN / LBS MAX**

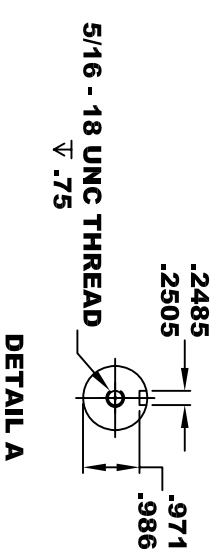
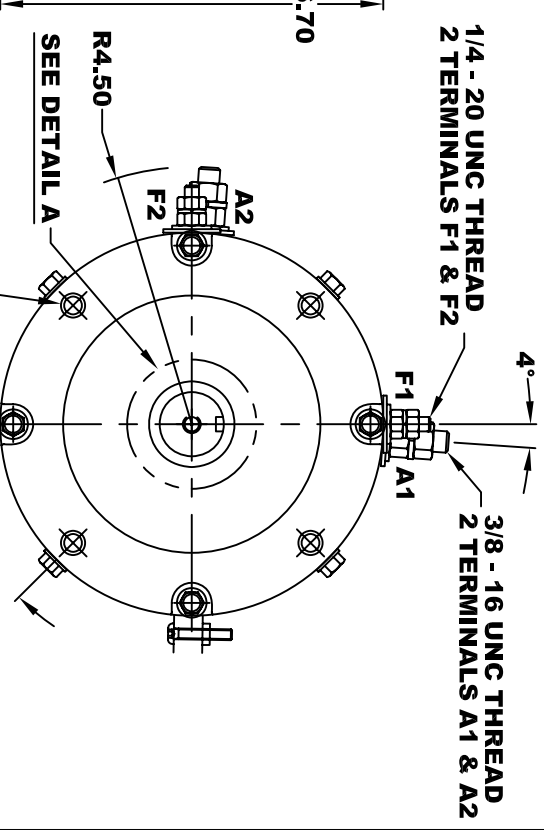
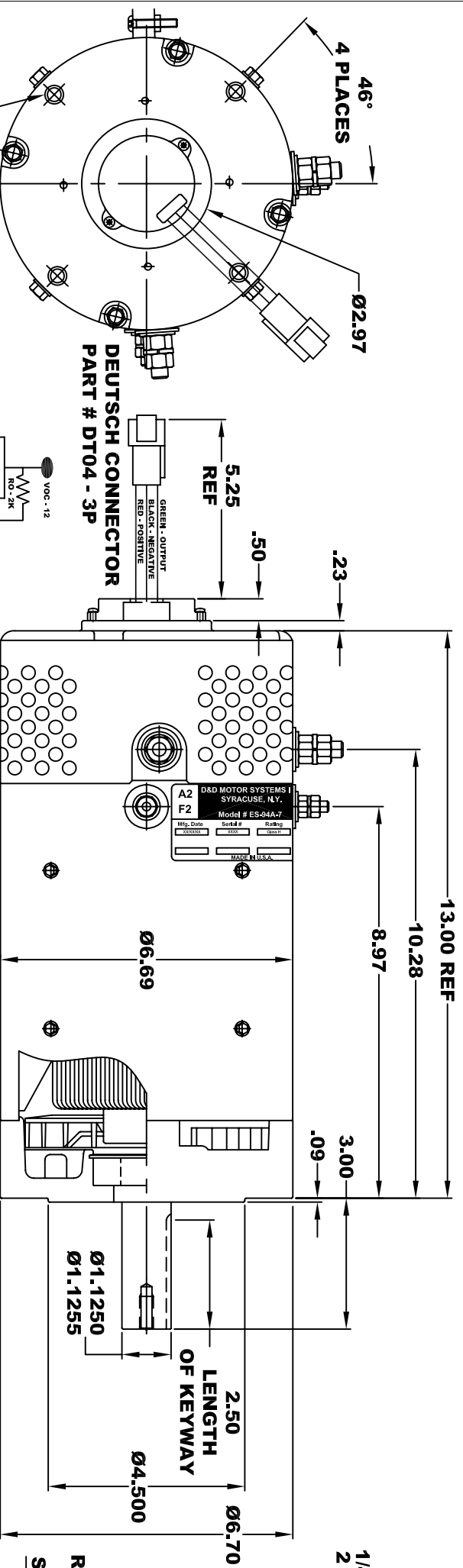

**SPEED SENSOR ELECTRICAL SPECIFICATION:**  
**4.5V TO 24V OPERATING VOLTAGE**  
**-20° C TO 85° C OPERATING TEMPERATURE**  
**-CURRENT SINKING UP TO 25mA**  
**-AN EXTERNAL OUTPUT PULL UP RESISTOR IS REQUIRED**  
**-SENSOR IS DESIGNED TO OPERATE WITH 4 N/S POLEPAIRS**  
**THE OPERATIONAL DISTANCE BETWEEN THE MAGNET**  
**AND THE HOUSING, INCLUDING ANY RUNOUT**  
**SHOULD NOT EXCEED .030 INCHES**

**MOTOR WEIGHT: 68 LBS**  
**CLASS "H" INSULATION**  
**PERFORMANCE SPEC: 7**

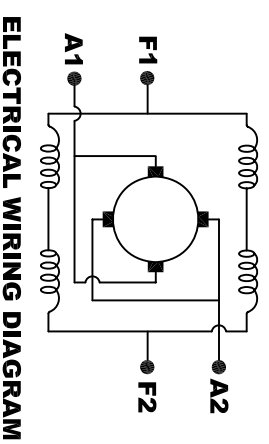

**MOTOR WIRING CONNECTIONS:**  
**CW ROTATION DRIVE END**  
**CONNECT A1 & F1 TO ONE BATTERY TERMINAL**  
**CCW ROTATION DRIVE END**  
**CONNECT A2 & F2 TO OTHER BATTERY TERMINAL**  
**SWITCH F1 & F2 CONNECTIONS**

**THIS PRINT IS THE PROPERTY OF D&D MOTOR SYSTEMS INC.**  
**DO NOT SCALE**  
**WORK TO DIMENSIONS**  
**TOLERANCES UNLESS OTHERWISE SPECIFIED ARE AS FOLLOWS**

.XX \_\_\_\_\_ .01  
 .XXX \_\_\_\_\_ .005  
 .XX ROUGH CASTING \_\_\_\_\_ .03  
 HOLES \_\_\_\_\_ -.001 / +.006  
 ANGLES \_\_\_\_\_ 0°30"

**D & D MOTOR SYSTEMS INC**

**MOTOR OUTLINE**

SIZE	DRAWN DATE	RELEASE DATE	DWG NO. / PART NO.	REV
B	1-22-10		ES-94A-7	
SCALE	STF	DRAWN BY	MJG	REV DATE