

<b>D&amp;D MOTOR SYSTEMS INC.</b>			
SYRACUSE N.Y.			
<b>A2</b>	<b>Model # ES-95-47</b>		<b>A1</b>
<b>F2</b>	Mfg. Date	Serial #	Rating
	XXXXXX	XXXX	CLASS HI
			Voltage
			XX
			MADE IN U.S.A.

**TORQUE SPECIFICATION FOR POWER CABLE SECURING TOP NUTS**  
 5/16-18 UNC (A1 / A2) - 110 IN / LBS MAX  
 1/4-20 UNC (F1 / F2) - 50 IN / LBS MAX

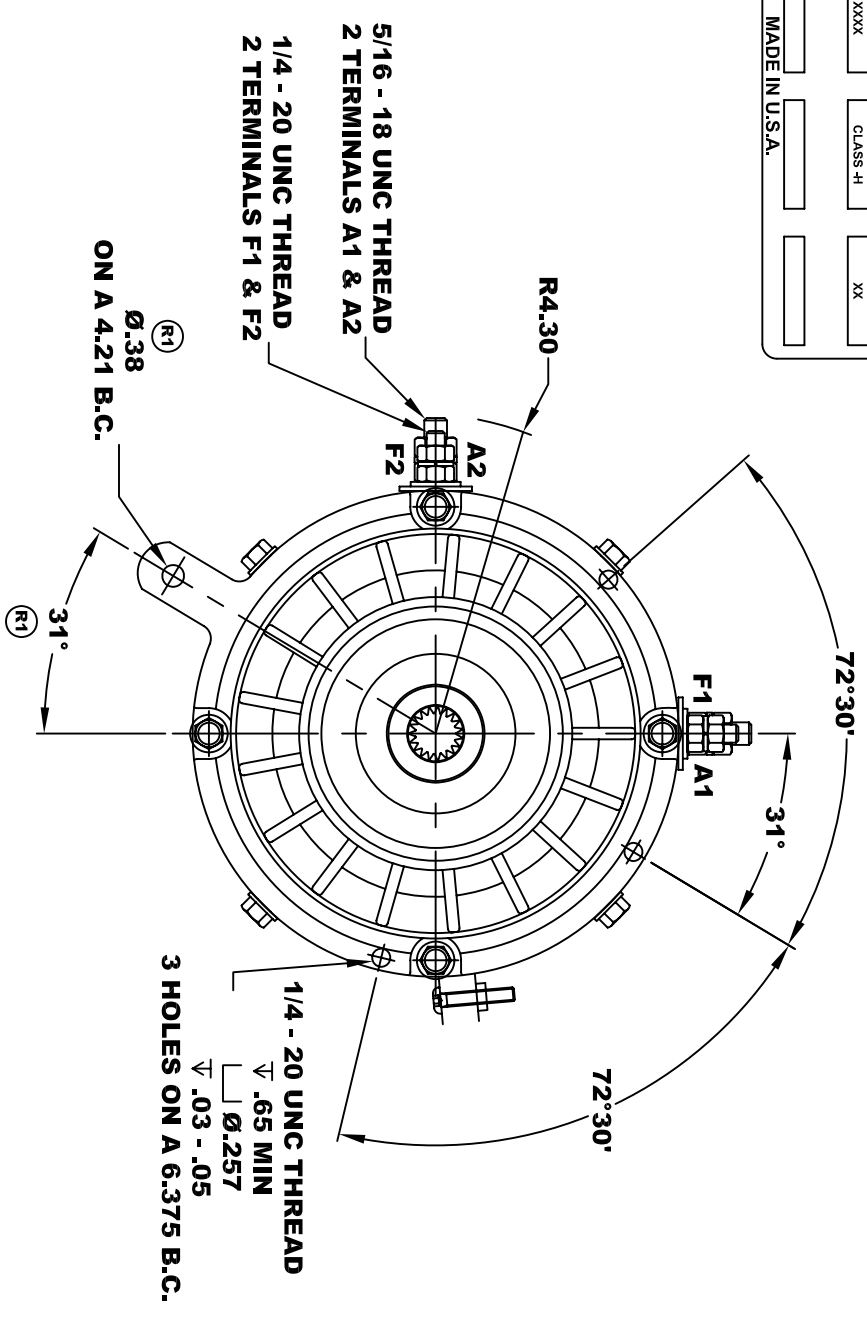

**ELECTRICAL SPECIFICATION:**  
 -4.5V TO 24V OPERATING VOLTAGE  
 -20°C TO 85°C OPERATING TEMPERATURE  
 -CURRENT SINKING UP TO 25mA  
 -AN EXTERNAL OUTPUT PULL UP RESISTOR IS REQUIRED  
 -SENSOR IS DESIGNED TO OPERATE WITH 4 N/S POLEPAIRS  
 THE OPERATIONAL DISTANCE BETWEEN THE MAGNET AND THE HOUSING, INCLUDING ANY RUNOUT SHOULD NOT EXCEED .030 INCHES

**INTERNAL INVOLUTE SPLINE SPECIFICATION**  
 CLASS 5 FILLET ROOT SIDE FIT (PER A.N.S.I. B92.1)

- NO. OF TEETH \_\_\_\_\_ 19
- SPLINE PITCH \_\_\_\_\_ 24 / 48
- PRESSURE ANGLE \_\_\_\_\_ 45°
- BASE Ø \_\_\_\_\_ .5597 REF
- PITCH Ø \_\_\_\_\_ .7916 REF
- MAJOR Ø \_\_\_\_\_ .850 - .859
- FORM Ø \_\_\_\_\_ .835
- MINOR Ø \_\_\_\_\_ .767 - .772
- CIRCULAR SPACE WIDTH \_\_\_\_\_ .0764
- EFFECTIVE SPACE WIDTH \_\_\_\_\_ .0738
- MAX. DIMENSION BETWEEN TWO PINS \_\_\_\_\_ .6714
- PIN Ø \_\_\_\_\_ .0800
- SPLINE HARDNESS TO BE R/C 26-34

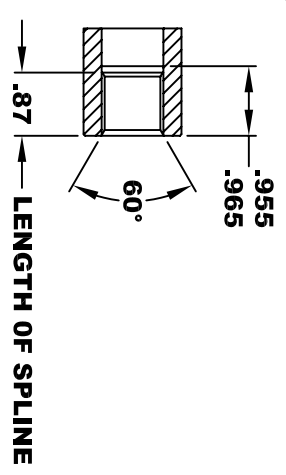

**MOTOR WEIGHT: 61 LBS**  
**CLASS "H" INSULATION**  
**PERFORMANCE SPEC: 47**

**ELECTRICAL WIRING DIAGRAM**

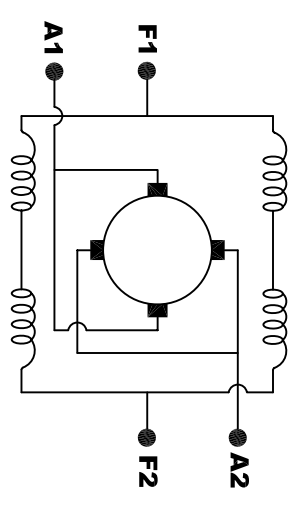

**MOTOR WIRING CONNECTIONS:**  
 CW ROTATION DRIVE END  
 CONNECT A1 & F1 TO ONE BATTERY TERMINAL  
 CONNECT A2 & F2 TO OTHER BATTERY TERMINAL  
 CCW ROTATION DRIVE END  
 SWITCH F1 & F2 CONNECTIONS

**D & D MOTOR SYSTEMS INC**

**MOTOR OUTLINE**

THIS PRINT IS THE PROPERTY OF D&D MOTOR SYSTEMS INC.  
 DO NOT SCALE  
 WORK TO DIMENSIONS  
 TOLERANCES UNLESS OTHERWISE SPECIFIED ARE AS FOLLOWS  
 .XX \_\_\_\_\_ .01  
 .XXX \_\_\_\_\_ .005  
 .XX ROUGH CASTING \_\_\_\_\_ .03  
 HOLES \_\_\_\_\_ -.001 / +.006  
 ANGLES \_\_\_\_\_ 0°30"

SIZE	DRAWN DATE	RELEASE DATE	DWG NO. / PART NO.	REV
B	3-14-05		ES-95-47	R2
SCALE	STF	DRAWN BY	MJG	REV DATE
				5-24-13