

<b>A2</b>		<b>D&amp;D MOTOR SYSTEMS INC.</b>		<b>A1</b>	
<b>F2</b>		<b>SYRACUSE N.Y.</b>		<b>F1</b>	
<b>Model # ES-9B-50</b>					
Mfg. Date	Serial #	Rating	Voltage		
XXXX/XX	XXXX	CLASS -H	XX		
MADE IN U.S.A.					

**TORQUE SPECIFICATION FOR  
POWER CABLE SECURING TOP NUTS**  
 5/16-18 UNC (A1 / A2) - 110 IN / LBS MAX  
 1/4-20 UNC (F1 / F2) - 50 IN / LBS MAX

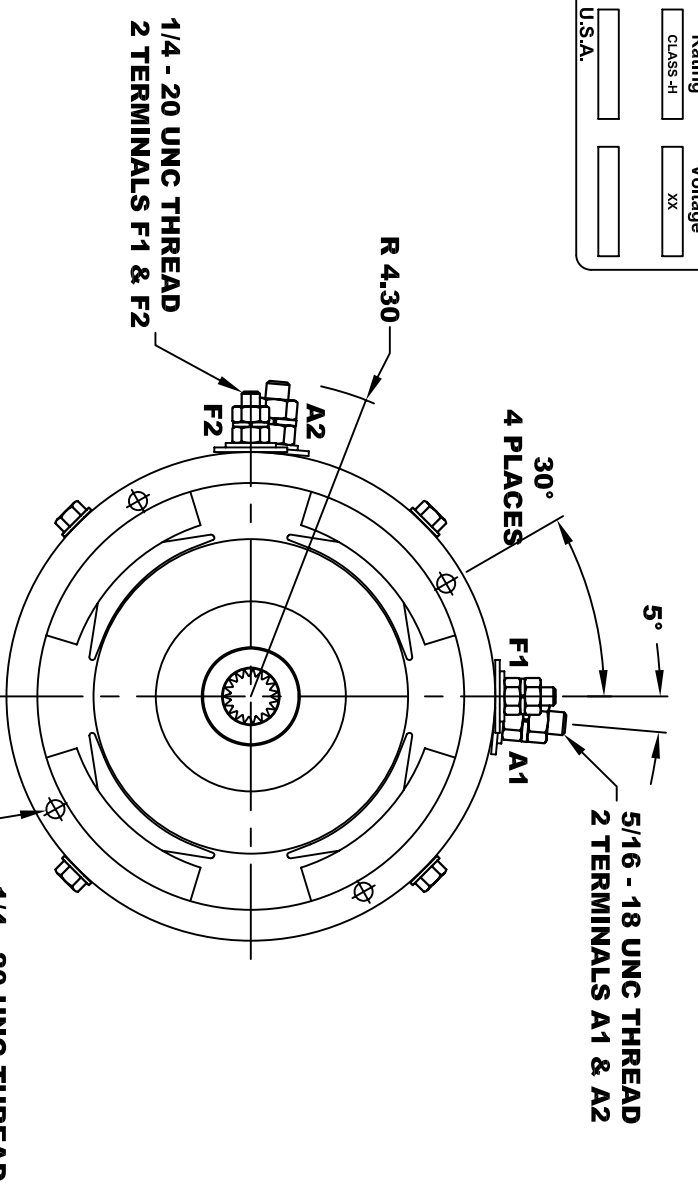
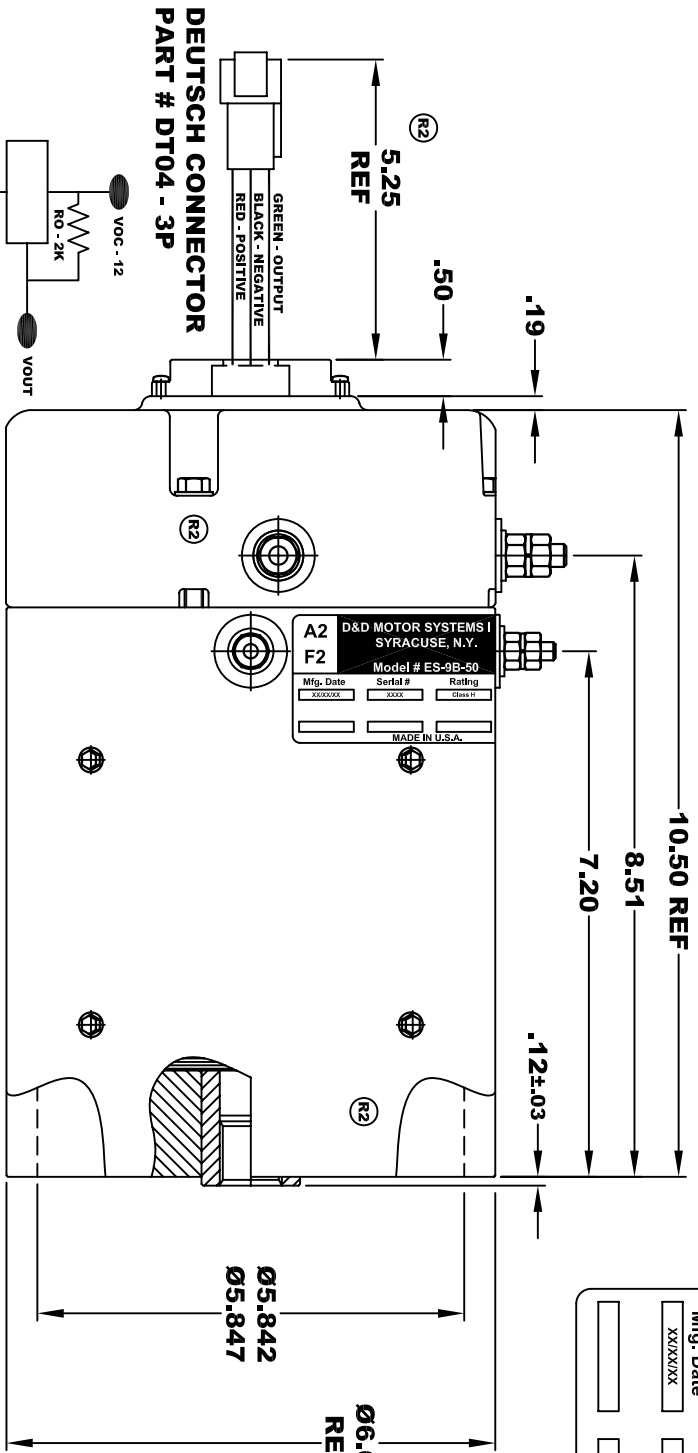

**SPEED SENSOR ELECTRICAL SPECIFICATION:**  
 -4.5V TO 24V OPERATING VOLTAGE  
 -20°C TO 85°C OPERATING TEMPERATURE  
 -CURRENT SINKING UP TO 25mA  
 -AN EXTERNAL OUTPUT PULL UP RESISTOR IS REQUIRED  
 -SENSOR IS DESIGNED TO OPERATE WITH 4 N/S POLEPAIRS  
 -THE OPERATIONAL DISTANCE BETWEEN THE MAGNET  
 AND THE HOUSING, INCLUDING ANY RUNOUT  
 SHOULD NOT EXCEED .030 INCHES

**INTERNAL INVOLUTE SPLINE SPECIFICATION  
 CLASS 5 FILLET ROOT SIDE FIT (PER A.N.S.I. B92.1)**

NO. OF TEETH	19
SPLINE PITCH	24 / 48
PRESSURE ANGLE	45°
BASE Ø	.5597 REF
PITCH Ø	.7916 REF
MAJOR Ø	.850 - .859
FORM Ø	.835
MINOR Ø	.767 - .772
CIRCULAR SPACE WIDTH	.0764
EFFECTIVE SPACE WIDTH	.0738
MAX. DIMENSION BETWEEN TWO PINS	.6714
PIN Ø	.0800
SPLINE HARDNESS TO BE R/C	26-34

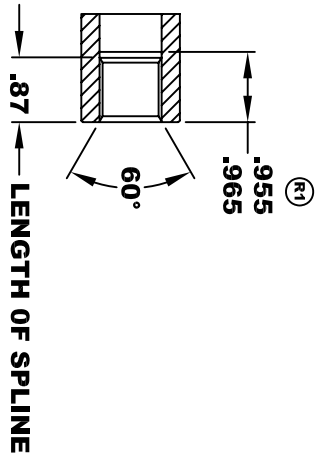

**MOTOR WEIGHT 57 LBS  
 CLASS "H" INSULATION  
 PERFORMANCE SPEC: 50**

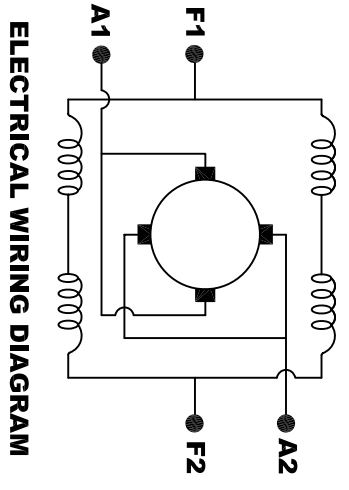

**MOTOR WIRING CONNECTIONS:**  
**CW ROTATION DRIVE END**  
 CONNECT A1 & F1 TO ONE BATTERY TERMINAL  
 CONNECT A2 & F2 TO OTHER BATTERY TERMINAL  
**CCW ROTATION DRIVE END**  
 SWITCH F1 & F2 CONNECTIONS

**D & D MOTOR SYSTEMS INC**  
**MOTOR OUTLINE**

THIS PRINT IS THE PROPERTY OF D&D MOTOR SYSTEMS INC.  
 DO NOT SCALE  
 WORK TO DIMENSIONS  
 TOLERANCES UNLESS OTHERWISE SPECIFIED ARE AS FOLLOWS  
 .XX \_\_\_\_\_ .01  
 .XXX \_\_\_\_\_ .005  
 .XX ROUGH CASTING \_\_\_\_\_ .03  
 HOLES \_\_\_\_\_ -.001 / +.006  
 ANGLES \_\_\_\_\_ 0°30"

SIZE	DRAWN DATE	RELEASE DATE	DWG NO. / PART NO.	REV
B	5-28-04		ES-9B-50	R2
SCALE	STF	DRAWN BY	MJG	REV DATE
				1-15-09