

D&D MOTOR SYSTEMS INC.			
SYRACUSE N.Y.			
A2	A1	F1	F2
Model # ES-9J-50			
Mfg. Date XXXXXX	Serial # XXXX	Rating CLASS -H	Voltage XX
MADE IN U.S.A.			

**TORQUE SPECIFICATION FOR
POWER CABLE SECURING TOP NUTS**
5/16-18 UNC (A1 / A2) - 110 IN / LBS MAX
1/4-20 UNC (F1 / F2) - 50 IN / LBS MAX

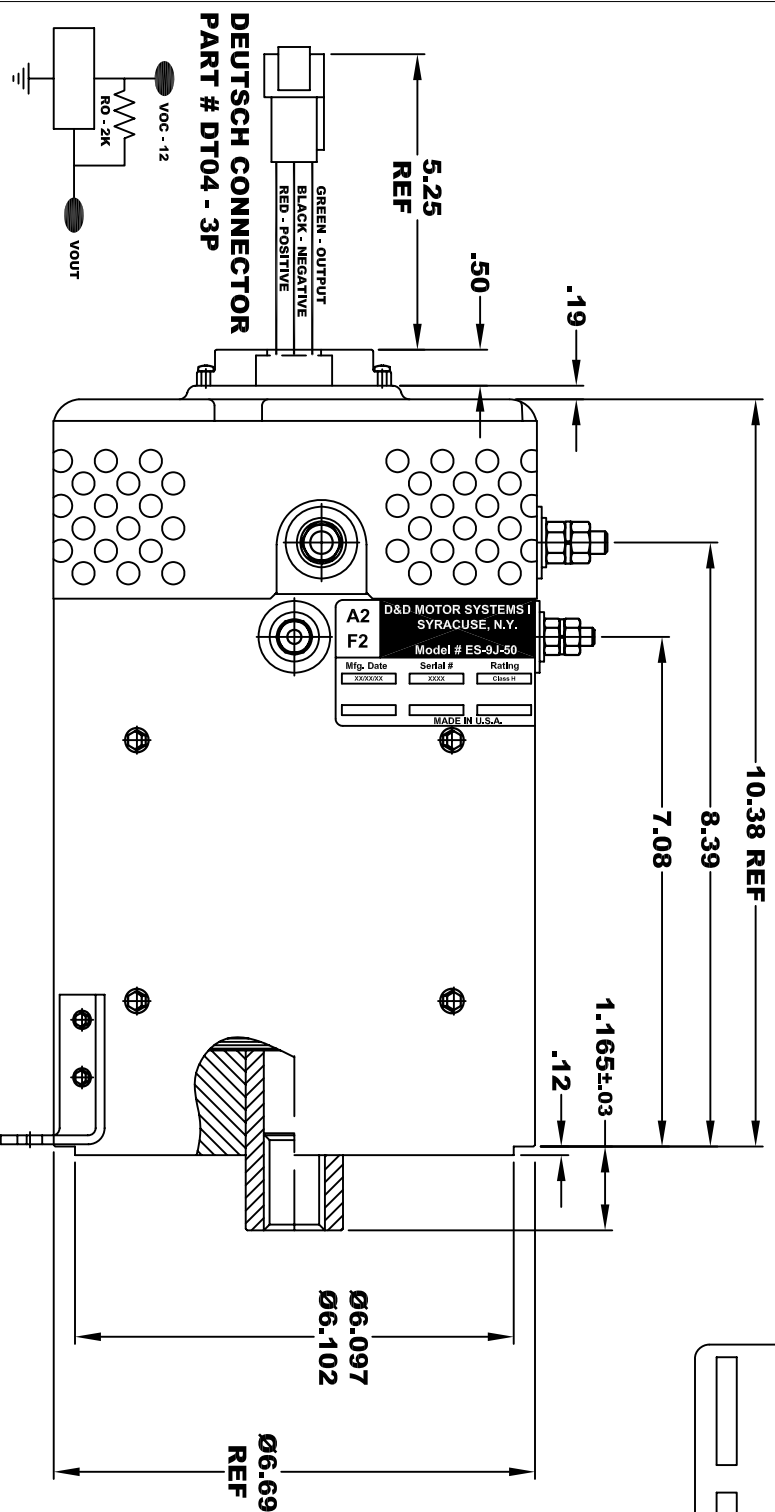

SPEED SENSOR ELECTRICAL SPECIFICATION:
 -4.5V TO 24V OPERATING VOLTAGE
 -20°C TO 85°C OPERATING TEMPERATURE
 -CURRENT SINKING UP TO 25mA
 -AN EXTERNAL OUTPUT PULL UP RESISTOR IS REQUIRED
 -SENSOR IS DESIGNED TO OPERATE WITH 4 N/S POLEPAIRS
 -THE OPERATIONAL DISTANCE BETWEEN THE MAGNET
 AND THE HOUSING, INCLUDING ANY RUNOUT
 SHOULD NOT EXCEED .030 INCHES

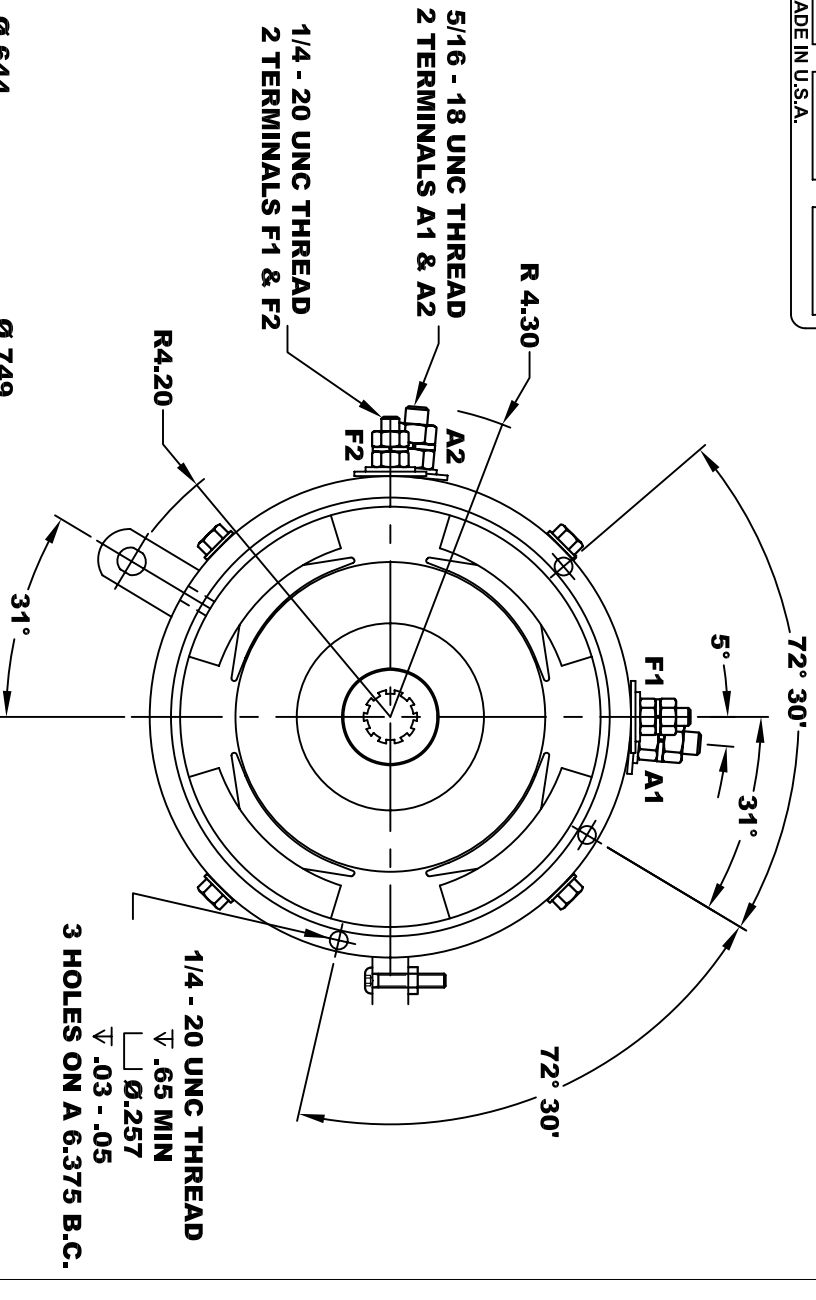
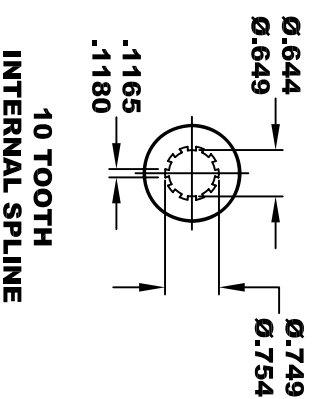
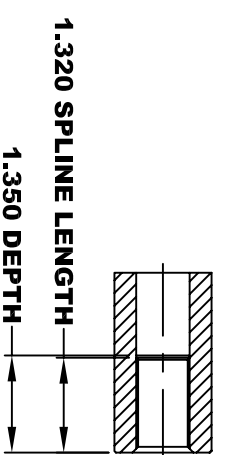

MOTOR WEIGHT 57 LBS
CLASS "H" INSULATION
PERFORMANCE SPEC: 50

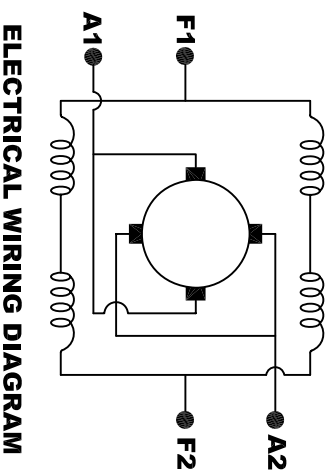

MOTOR WIRING CONNECTIONS
CW ROTATION DRIVE END
CONNECT A1 & F1 TO ONE BATTERY TERMINAL
CCW ROTATION DRIVE END
CONNECT A2 & F2 TO OTHER BATTERY TERMINAL

THIS PRINT IS THE PROPERTY OF D&D MOTOR SYSTEMS INC.
 DO NOT SCALE
 WORK TO DIMENSIONS
 TOLERANCES UNLESS OTHERWISE SPECIFIED ARE AS FOLLOWS
 .XX _____ .01
 .XXX _____ .005
 .XX ROUGH CASTING _____ .03
 HOLES _____ -.001 / +.006
 ANGLES _____ 0°30'

D & D MOTOR SYSTEMS INC			
MOTOR OUTLINE			
SIZE	DRAWN DATE	RELEASE DATE	DWG NO. / PART NO.
B	11-12-09		ES-9J-50
SCALE	STF	DRAWN BY	MJG
			REV DATE