

D&D MOTOR SYSTEMS INC.			
SYRACUSE N.Y.			
A2	F2	A1	F1
Model # ES-XX			
Mfg. Date	Serial #	Rating	Voltage
XXXXXX	XXXX	CLASSH	XX
MADE IN U.S.A.			

**TORQUE SPECIFICATION FOR
POWER CABLE SECURING TOP NUTS**
5/16-18 UNC (A1 / A2) - 110 IN / LBS MAX
1/4-20 UNC (F1 / F2) - 50 IN / LBS MAX

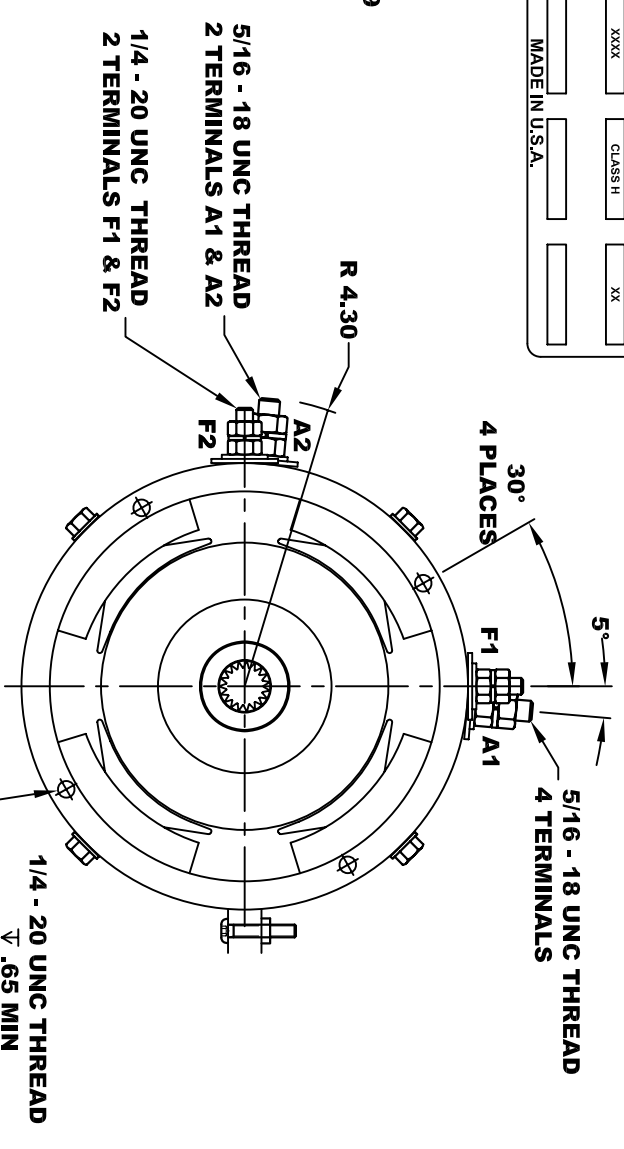
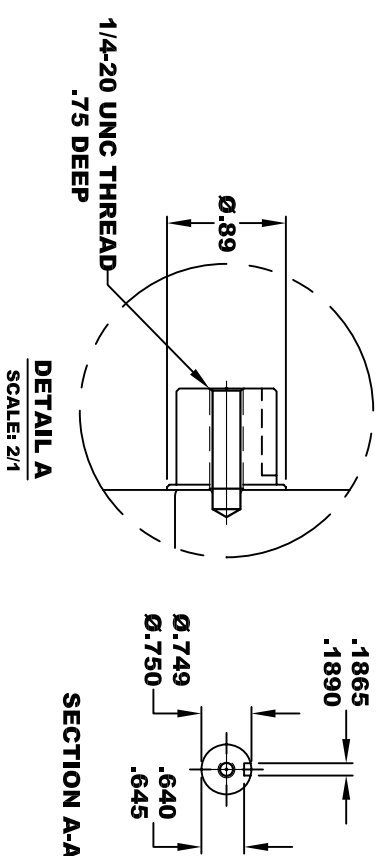
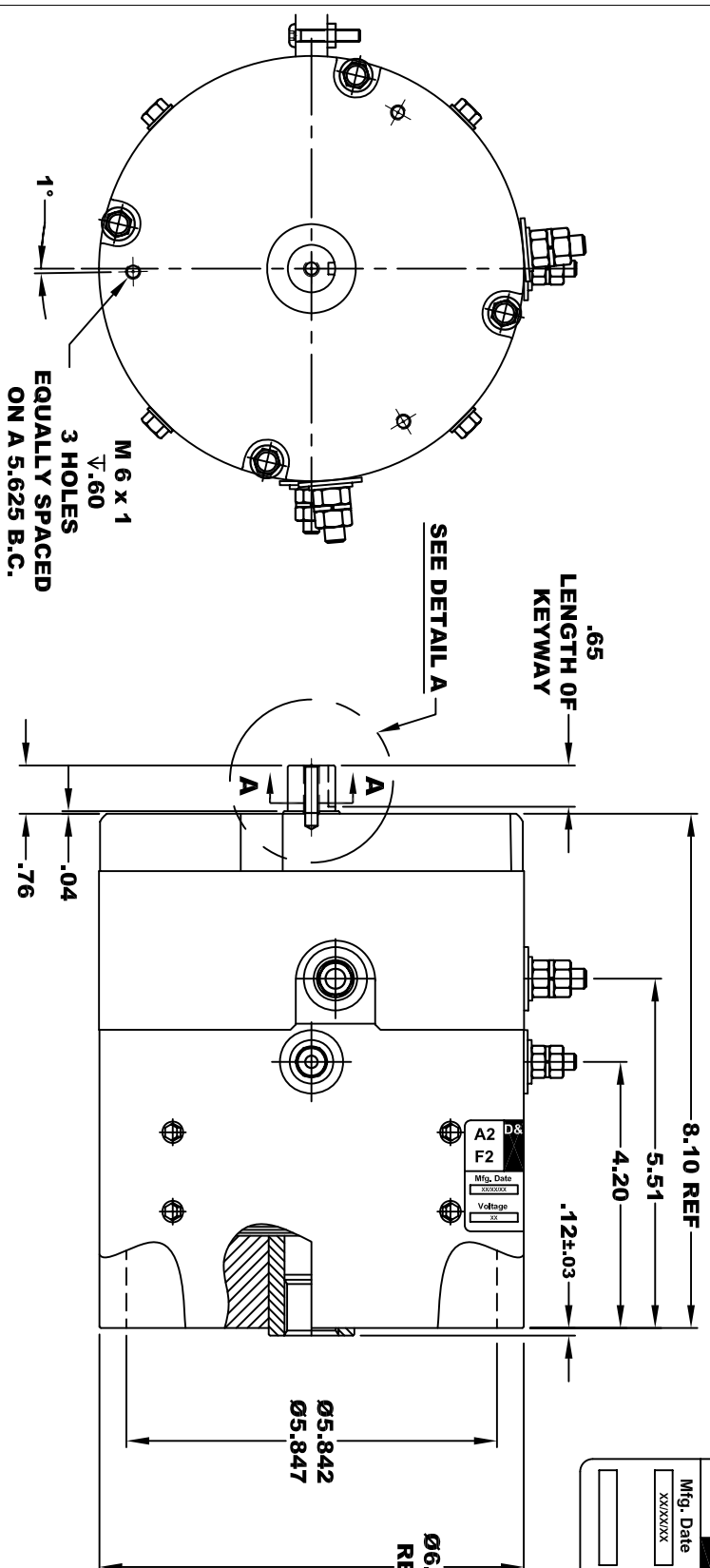

**INTERNAL INVOLUTE SPLINE SPECIFICATION
CLASS 5 FILET ROOT SIDE FIT (PER A.N.S.I. B92.1)**

NO. OF TEETH	19
SPLINE PITCH	24 / 48
PRESSURE ANGLE	45°
BASE Ø	.5597 REF
PITCH Ø	.7916 REF
MAJOR Ø	.850 - .859
FORM Ø	.835
MINOR Ø	.767 - .772
CIRCULAR SPACE WIDTH	.0764
EFFECTIVE SPACE WIDTH	.0738
MAX. DIMENSION BETWEEN TWO PINS	.6714
PIN Ø	.0800
SPLINE HARDNESS TO BE R/C 26-34	

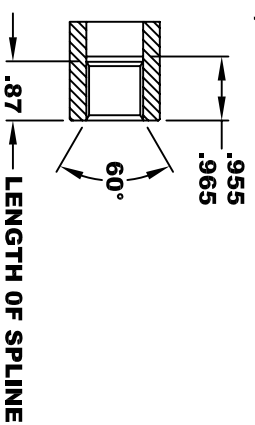

MOTOR WEIGHT 52 LBS
CLASS "H" INSULATION
PERFORMANCE SPEC: XX

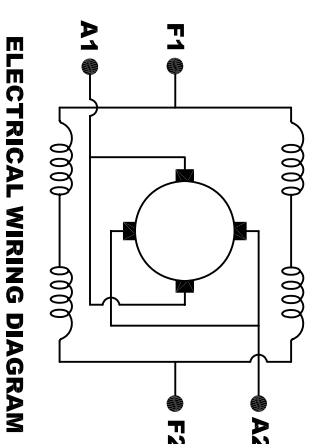

MOTOR WIRING CONNECTIONS:
CW ROTATION DRIVE END
CONNECT A1 & F1 TO ONE BATTERY TERMINAL
CONNECT A2 & F2 TO OTHER BATTERY TERMINAL
CCW ROTATION DRIVE END
SWITCH F1 & F2 CONNECTIONS

THIS PRINT IS THE PROPERTY OF D&D MOTOR SYSTEMS INC.
 DO NOT SCALE
 WORK TO DIMENSIONS
 TOLERANCES UNLESS OTHERWISE SPECIFIED ARE AS FOLLOWS
 .XX _____ .01
 .XXX _____ .005
 .XX ROUGH CASTING _____ .03
 HOLES _____ -.001 / +.006
 ANGLES _____ 0°30"

D & D MOTOR SYSTEMS INC
MOTOR OUTLINE

SIZE	DRAWN DATE	RELEASE DATE	DWG NO. / PART NO.	REV
B	8-8-08		ES-XX	
SCALE	STF	DRAWN BY	MJG	REV DATE